



Network Slicing Landscape:

A holistic architectural approach, orchestration and management with applicability in mobile and fixed networks and clouds

Version V1.0 29th June 2018



Prof. Alex Galis

University College London, UK

a.galis@ucl.ac.uk



Kiran Makhijani

Principal Research Scientist Huawei USA

Kiran.Makhijani@huawei.com

Contents List

1. Key Slicing concepts and history
2. Slicing Key Characteristics & Usage scenarios & Value Chain
3. Multi-Domain Network Function Virtualisation
4. Review of Research projects and results in network and cloud slicing
5. Open Source Orchestrators
6. Standard Organization activities: NGMN, ITU-T, ONF, 3GPP, ETSI, BBF, IETF
7. Industrial perspective on Network Slicing
8. Review of industry Use Cases
9. Network Slicing Challenges
10. Concluding remarks of Network Slicing
11. Acknowledgements & References

5G Networking Infrastructure Ecosystem

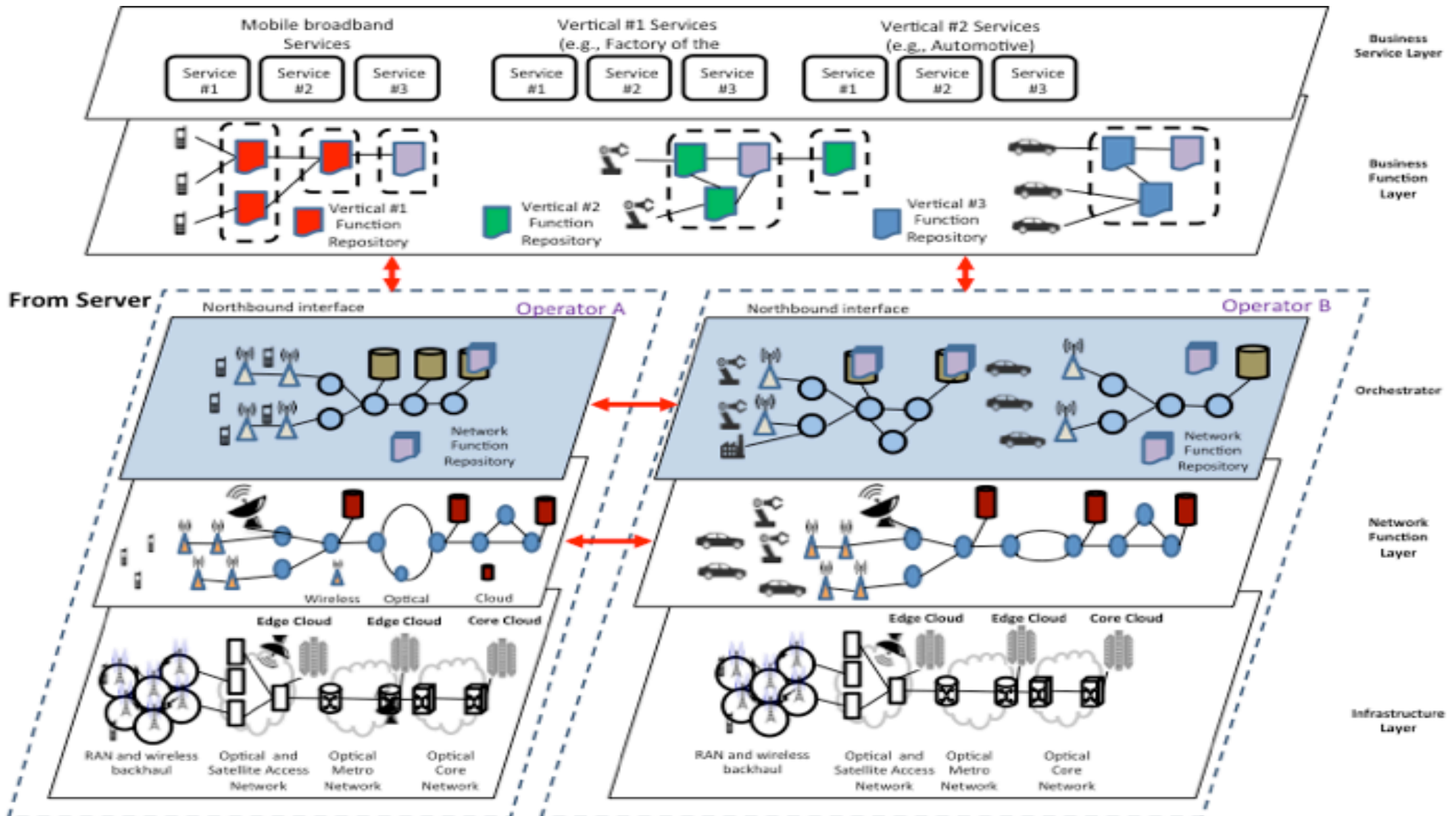

Roles & Concepts (I)

Roles

- **Infrastructure Owner** Owns the physical infrastructure (network/cloud/datacentre) and lease them to operators. It becomes an ISP if it lease the infrastructure in network slicing fashion.
- **Infrastructure Slice Provider** – An infrastructure slice provider (ISP), typically a telecommunication service provider, is the owner or tenant of the infrastructures from which network slices can be created.
- **Infrastructure Slice Tenant** – An infrastructure slice tenant (IST) is the user of specific network/cloud/datacentre slice, in which customized services are hosted. Infrastructure slice tenants can make requests of the creation of new infrastructure slice through a service model.

Concepts:

- **Infrastructure Slice** - A set of infrastructure (network, cloud, datacentre) components/network functions, infrastructure resources (i.e. managed connectivity, compute, storage resources) and service functions that has attributes specifically designed to meet the needs of an industry vertical or a service.
- **Infrastructure Slicing** - A management mechanism that Infrastructure Slice Provider can use to allocate dedicated infrastructure resources and service functions to Network Slice Tenant.
- **Partition Types**
 - Physical separation (e.g., dedicated backbones) → not cost efficient
 - *A resource only partition is one of the components of a Network Slice, however on its own does not fully represent a Network Slice.*
 - *Underlays / overlays supporting all services equally (“best effort” support) are not fully representing a Network Slice.*
 - *Underlays / overlays, in the form of VPN as overlay solution → not flexible nor agile*
 - Slicing, through network resource (including SF) allocation → dedicated resources per customer/service to ensure isolation on top of the same infrastructure

Driving issue: *It is inefficient and expensive to build a separate infrastructure for each service.*

Concepts (II)



Network Slice – A Network Slice is a **managed group of subsets of resources, network functions / network virtual functions at the data, control, management/orchestration, and service planes at any given time**. The behaviour of the network slice is realized via network slice instances (i.e. activated network slices, dynamically and non-disruptively re-provisioned).

- A network slice is programmable and has the ability to expose its capabilities.
 - An end-to-end logical network/cloud running on a common underlying (physical or virtual) infrastructure, mutually isolated, with independent control and management that can be created on demand.
-
- *A network slice supports at least one type of service.*
 - *A network slice may consist of cross-domain components from separate domains in the same or different administrations, or components applicable to the access network, transport network, core network, and edge networks.*
 - *A resource only partition is one of the components of a Network Slice, however on its own does not fully represent a Network Slice.*
 - *Underlays / overlays supporting all services equally (“best effort” support) are not fully representing a Network Slice.*

Concepts (III)

Additional viewpoints:

- From a **business point of view**, a **slice** includes *a combination of all the relevant network resources, functions, and assets required to fulfill a specific business case or service, including OSS, BSS and DevOps processes.*
- From the **infrastructure point of view**, **infrastructure slice instances** require *the partitioning and assignment of a set of resources that can be used in an isolated, disjunctive or non- disjunctive manner for that slice.*
- From the **tenant point of view**, **infrastructure slice instance provides** different capabilities, specifically in terms of their management and control capabilities, and how much of them the network service provider hands over to the slice tenant. As such there are two types of slices:
 - (1) **Internal slices**, understood as *the partitions used for internal services of the provider, retaining full control and management of them.*
 - (2) **External slices**, being those *partitions hosting customer services, appearing to the customer as dedicated networks/clouds/datacentres.*
- From the **management plane point of view**, **infrastructure slices** refers to the managed fully functional *dynamically created partitions of physical and/or virtual network resources, network physical/virtual and service functions that can act as an independent instance of a connectivity network and/or as a network cloud.* Infrastructure resources include connectivity, compute, and storage resources.
- From the **data plane point of view**, **infrastructure slices** refers to *dynamically created partitions of network forwarding devices with guarantees for isolation and security.*

Concepts (IV)

Novel solutions in search of flexibility, agility, cost efficiency \mapsto **Network Slicing**

Services & Vertical industries may bring diverging use cases and application scenarios

Network slice are:

- Self-contained
- Mutually isolated
- Manageable & Programmable
- Support for multi-service
- Support for multi-tenancy

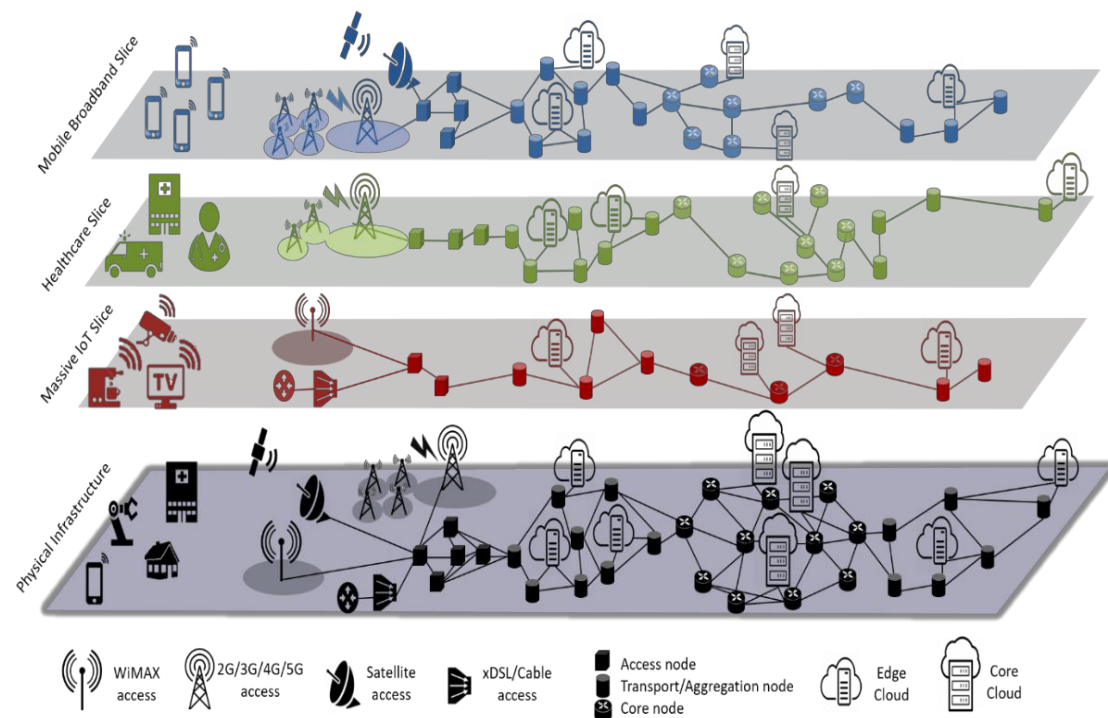

Concepts (V)

Network Slice Types Vs. Management Responsibilities

Network Slice Types

External
Tenant
Managed
Slices

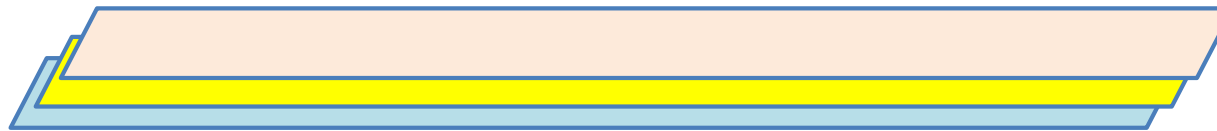

External
Provider
Managed
Slices



Provider
Slice As A
Service



Provider
Internal
Slices

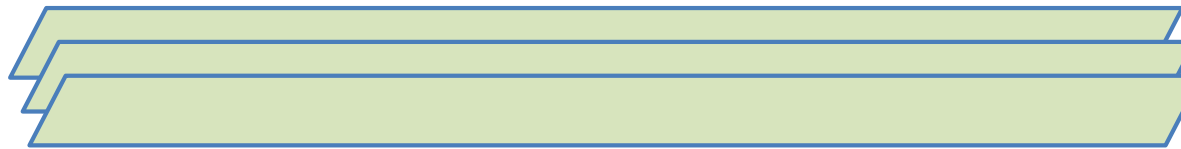

Management Responsibilities

Tenant
Manages
Slices and
Services

Provider
Manages
Slices and
Tenant
Manages
Services

Provider
Manages
Slices as a
Service

Provider
Manages
Slices and
Services

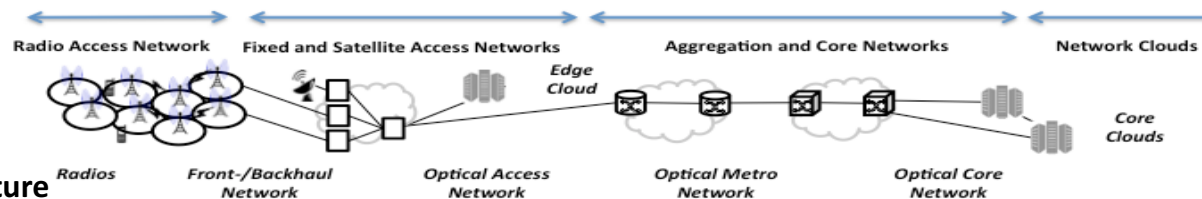

Infrastructure

Concepts (VI)

Network Slice Representation

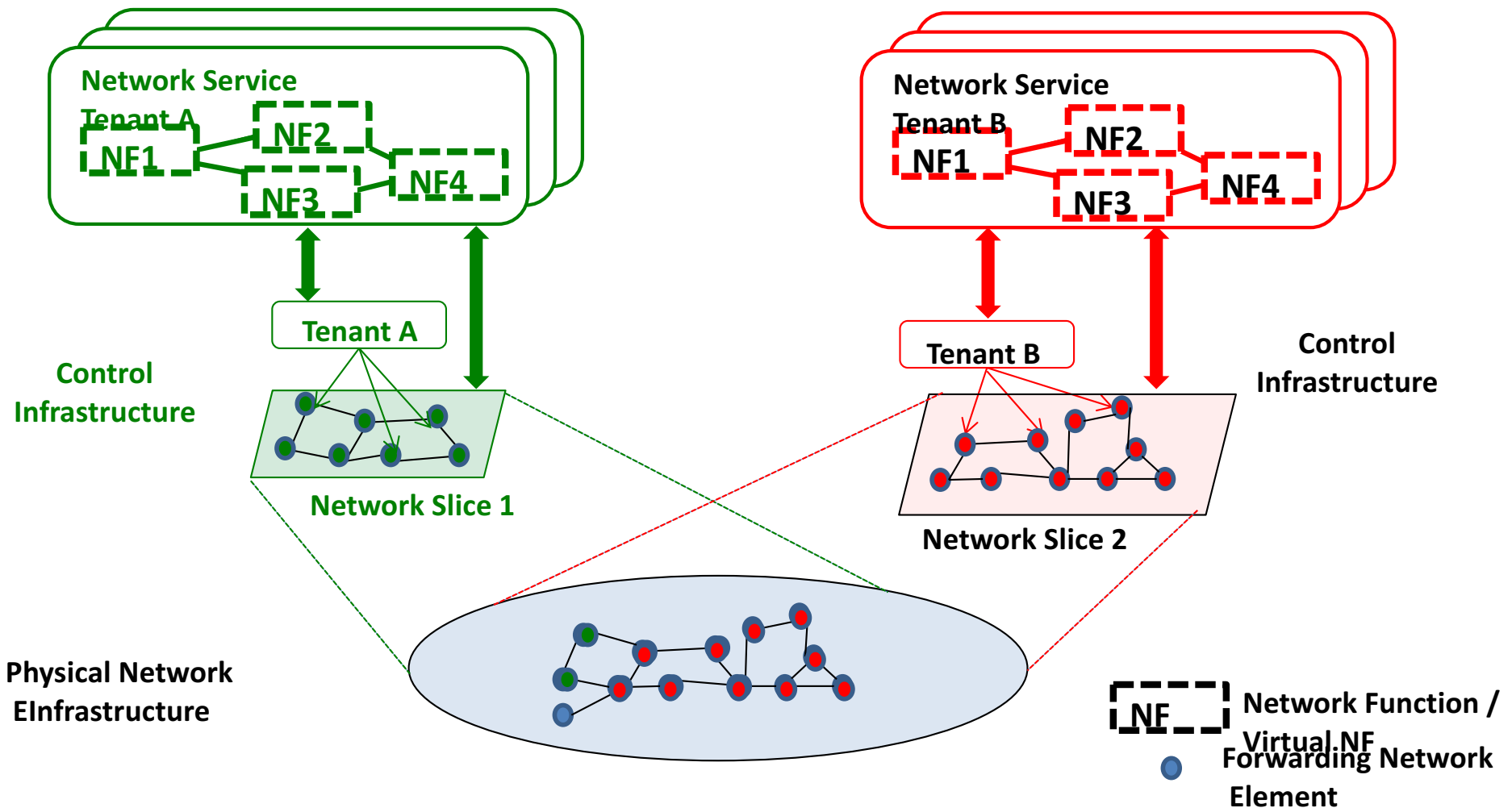

Concepts (VII)

Cross-domain management of network slices in network infrastructure and service functions

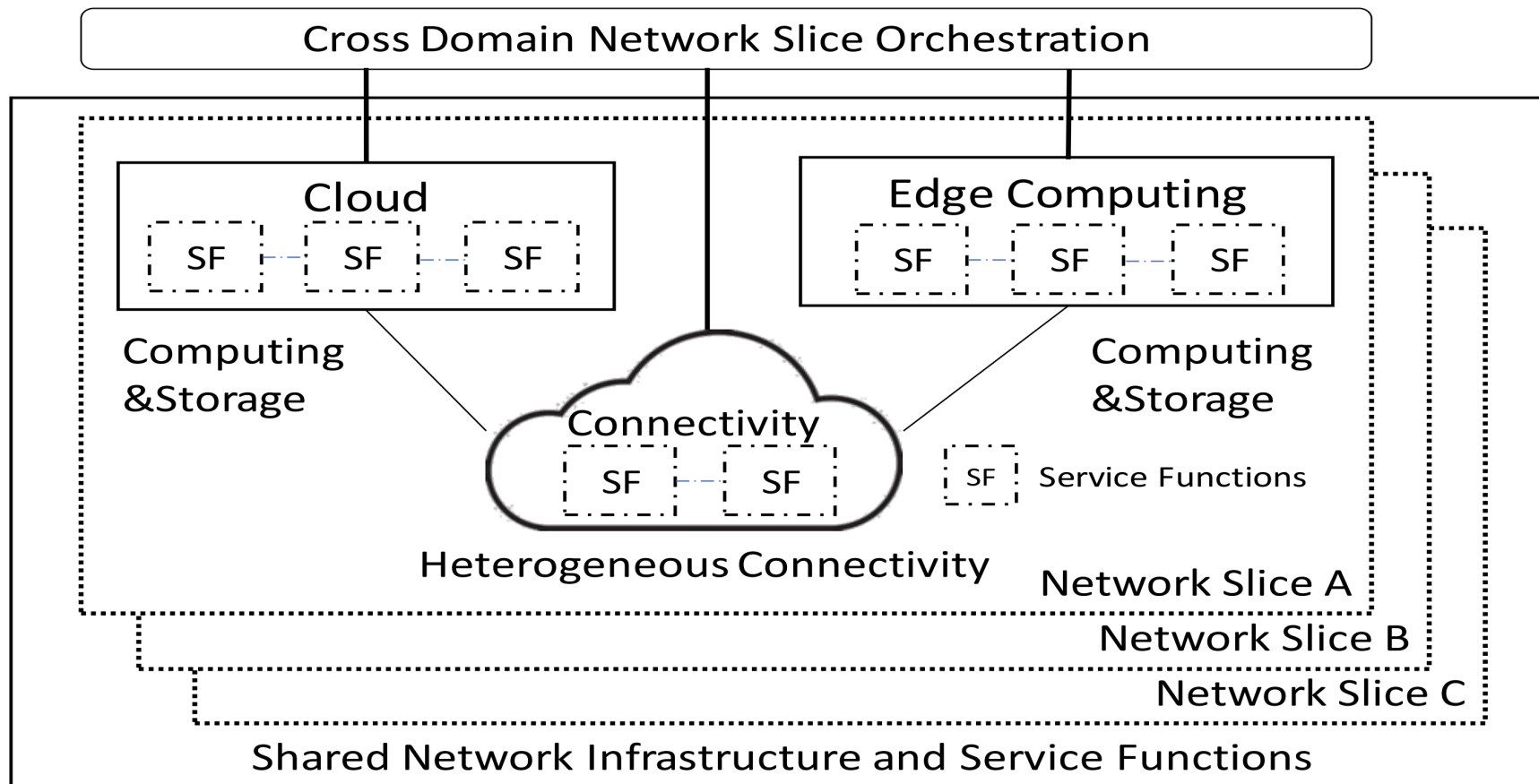

Slicing Key Characteristics & Impact

- **A managed group of infrastructure resources, network functions and services** (e.g. Service Instance component, A Network Slice Instance component, Resources component , Slice Capability exposure component).
- Concurrent deployment of **multiple logical, self-contained and independent, shared or partitioned networks on a common infrastructure platform.**
- **is a dedicated network** part that is built on an infrastructure mainly composed of, but not limited to, connectivity, storage, and computing.
- **it is related to an operator** that sees it as a complete network infrastructure and uses part of the network resources to meet stringent resource requirements.
- Supports **dynamic multi-service support, many/multi-tenancy** and the integration means for vertical market players.
- **NS is programmable and has the ability to expose its capabilities.** The behavior of the network slice realized via network slice instance(s).
- **Service customized Network Slices (enabled by NFV) + Smart Network Fabric for coordinating/orchestration, control of network resource**
- **Guaranteeing service level for end to end across multiple (administrative) domains**
- **Flexible customizability**
 - automation as the way for simplifying the provisioning

Slicing Key Characteristics & Impact (2)



- **NS has dynamic and non-disruptive re-provisioning.**
- **Automation of network operation**
- **Automated life-cycle management of network slicing (Deploy, Change, Delete)**
 - Optimization resources (Auto-scaling/migration)
 - Auto-healing
 - Efficient Interplay between Management and Data Planes
- **High-Scalability**
 - Separating to 100~ slices (the order will vary depending on the use cases)
 - Handling million ordered customers
- **High-Reliability**
 - Redundant mechanisms
 - High Level of Isolation
 - Immediate fault detection
- **Network Slicing with cross-domain by using open network configuration model design**
- **Cost effective and prompt service/network deployment**
 - Utilization of virtualizing technologies (SDN and NFV)
 - Harmonizing hardware and software appliances

Slicing Key Characteristics & Impact (3)



- **Network operators/ ISP can exploit network slicing for**
 - Enables other industrial companies to use networks as a part of their own services (e.g. vertical players: connected car with high reliable network, online game with ultra-low latency, video streaming with guaranteed bandwidth, etc.)
 - reducing significantly operations expenditures, allowing also programmability necessary to enrich the offered tailored services.
 - means for network programmability to OTT providers and other market players without changing the physical infrastructure.
- **NS** simplifies the provisioning of services, manageability of networks and integration and operational challenges especially for supporting communication services.
- **Expecting realization of E2E network slices and creation of new business model**
- **introduces an additional layer of abstraction** by the creation of logically or physically isolated groups of network resources and (virtual) network functions configurations.
- **Considerably transform the networking perspective** by
 - abstracting, isolating, orchestrating and separating logical network behaviors from the underlying physical network resources.

Slices Usage Scenarios

- Mission-critical Ultra low latency communication
- Massive-connectivity machine communication (e.g. Smart metering, Smart grid and sensor networks)
- Extreme QoS
- Independent QoS isolation design
- Independent operations and management
- Independent autonomic management functionality
- Independent cost and/or energy optimization
- Independent multi-topology routing
- Sharing Infrastructure: Enablers for sharing infrastructure safely and efficiently (Multi-tenant)

Network Slicing Value Chain

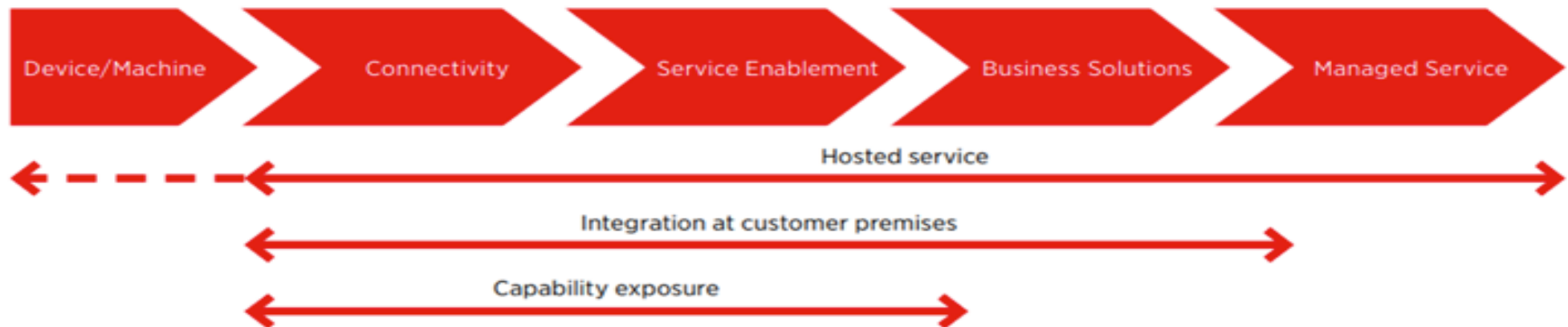

- **Capability exposure:** through this utilization model, the providers can offer Application Programming Interfaces (APIs) to the vertical business customers for granting the capability of managing their own slices. Such management actions can include e.g. dimensioning, configuration, etc.
- **Integration at customer premises:** complementary network segments, in some cases pertaining to the vertical business customer, become an integral part of the solution, requiring a truly convergent network including the integration in existing business processes as defined by the vertical customer.
- **Hosting applications:** the provider offer the capability of hosting virtualized versions of network functions or applications, including the activation of the necessary monitoring information for those functions.
- **Hosting on-demand 3rd parties /OTTs:** empower partners (3rd parties / OTTs) to directly make offers to the end customers augmenting operator network or other value creation capabilities.

Early Definitions of Network Slicing & References (I)



Active / Programmable Networks research: node operating systems & resource control frameworks (1995 -2005) (*)

Federated Testbed research : Planet Lab USA (2002), PlanetLab EU (2005), OneLab EU (2007), PlanetLab Japan (2005), OpenLab EU (2012)

GENI Slice (2008): “GENI is a shared network testbed i.e. multiple experimenters may be running multiple experiments at the same time. A GENI slice is:

- The unit of isolation for experiments.
- A container for resources used in an experiment. GENI experimenters add GENI resources (compute resources, network links, etc..) to slices and run experiments that use these resources.
- A unit of access control. The experimenter that creates a slice can determine which project members have access to the slice i.e. are members of the slice.

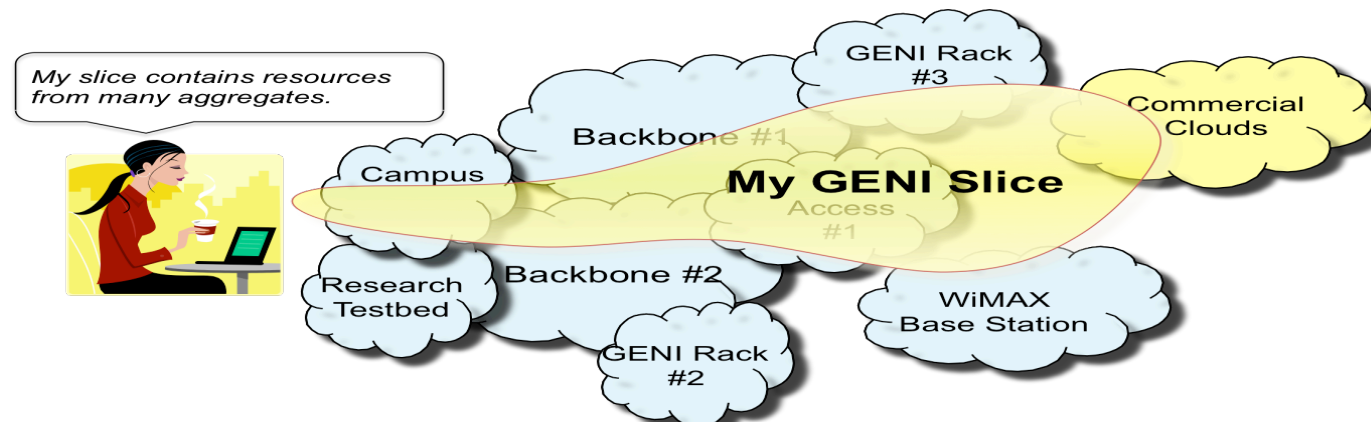

(*) Galis, A., Denazis, S., Brou, C., Klein, C. (ed) –“Programmable Networks for IP Service Deployment” ISBN 1-58053-745-6, pp 450, June 2004, Artech House Books, <http://www.artechhouse.com/International/Books/Programmable-Networks-for-IP-Service-Deployment-1017.aspx>

Early Definitions of Network Slicing & References(II)



Slice capabilities (2009) “Management and Service-aware Networking Architectures (MANA) for Future Internet” – A. Galis et al - Invited paper IEEE 2009 Fourth International Conference on Communications and Networking in China (ChinaCom09) 26-28 August 2009, Xi'an, China, <http://www.chinacom.org/2009/index.html>

3 Slices Capabilities

- “Resource allocation to virtual infrastructures or slices of virtual infrastructure.”
- “Dynamic creation and management of virtual infrastructures/slices of virtual infrastructure across diverse resources.”
- “Dynamic mapping and deployment of a service on a virtual infrastructure/slices of virtual infrastructure.”

17 Orchestration capabilities

19 Self-functionality mechanisms

14 Self-functionality infrastructure capabilities

ITU-T Slicing (2011) as defined in [ITU-T Y.3011- <http://www.itu.int/rec/T-REC-Y.3001-201105-I>] is the basic concept of the Network Softwarization. Slicing allows logically isolated network partitions (LINP) with a slice being considered as a unit of programmable resources such as network, computation and storage.

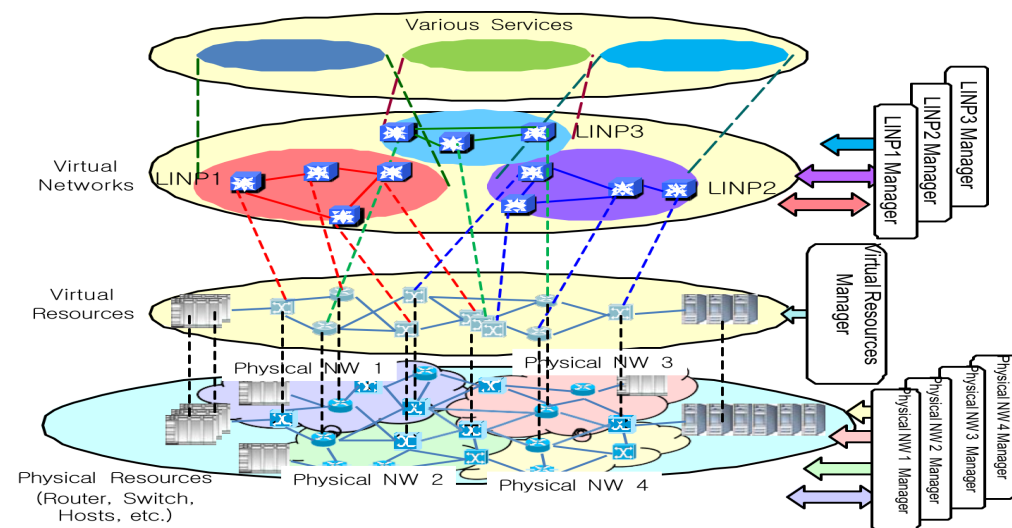

Early Definitions of Network Slicing & References (III)



NGMN Slice capabilities (2016) - consist of 3 layers: 1) Service Instance Layer, 2) Network Slice Instance Layer, and 3) Resource layer.

- The Service Instance Layer represents the services (end-user service or business services) which are to be supported. Each service is represented by a Service Instance. Typically services can be provided by the network operator or by 3rd parties.
- A Network Slice Instance provides the network characteristics which are required by a Service Instance. A Network Slice Instance may also be shared across multiple Service Instances provided by the network operator.
- The Network Slice Instance may be composed by none, one or more Sub-network Instances, which may be shared by another Network Slice Instance.

3GPP TR23.799 Study Item “Network Slicing” 2016

ONF Recommendation TR-526 “Applying SDN architecture to Network Slicing” 2016

EU 5GPPP

- **15 Large Scale Research projects – all based on Network Slicing** (<https://5g-ppp.eu>) **(2015- 2018+)**
- **White Papers on 5G Architecture centered on network slicing** (mark 1 - <https://5g-ppp.eu/wp-content/uploads/2014/02/5G-PPP-5G-Architecture-WP-July-2016.pdf>) **(2016)** (mark 2 <https://5g-ppp.eu/wp-content/uploads/2018/01/5G-PPP-5G-Architecture-White-Paper-Jan-2018-v2.0.pdf>) **(2018)**

C-RAN Virtualization & Slicing under Software Control

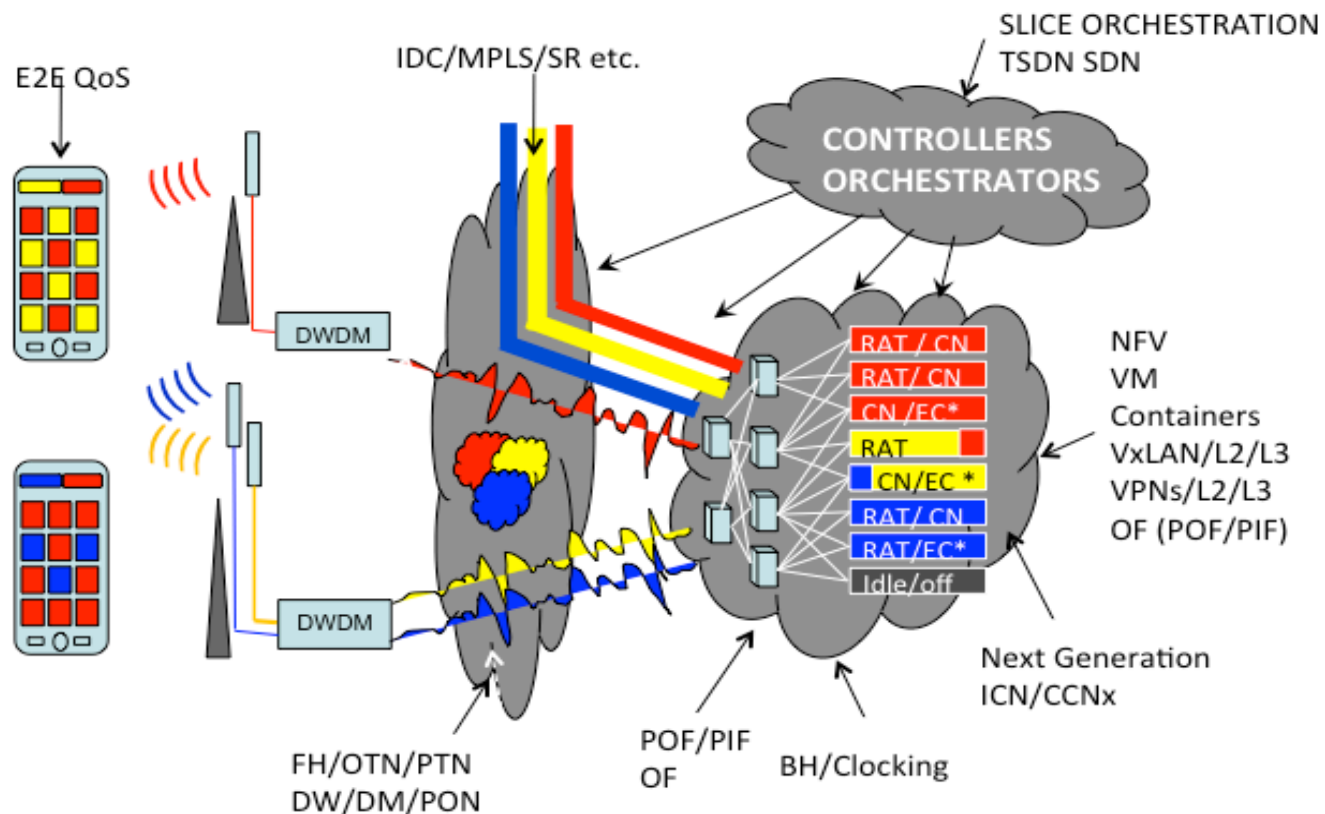

*EC = Mobile edge computing and distribute cloud

Example of 5G C-RAN network slicing

(Report of Gap Analysis – Focus group on IMT-2020– Nov 15 T13-SG13-151130-TD-PLN-0208!!MSW-E.docx)

Contents List

1. Key Slicing concepts and history
2. Slicing Key Characteristics & Usage scenarios & Value Chain
3. Multi-Domain Network Function Virtualisation
4. Review of Research projects and results in network and cloud slicing
5. Open Source Orchestrators
6. Standard Organization activities: NGMN, ITU-T, ONF, 3GPP, ETSI, BBF, IETF
7. Industrial perspective on Network Slicing
8. Review of industry Use Cases
9. Network Slicing Challenges
10. Concluding remarks of Network Slicing
11. Acknowledgements & References

Overall ETSI NFV MANO Architecture

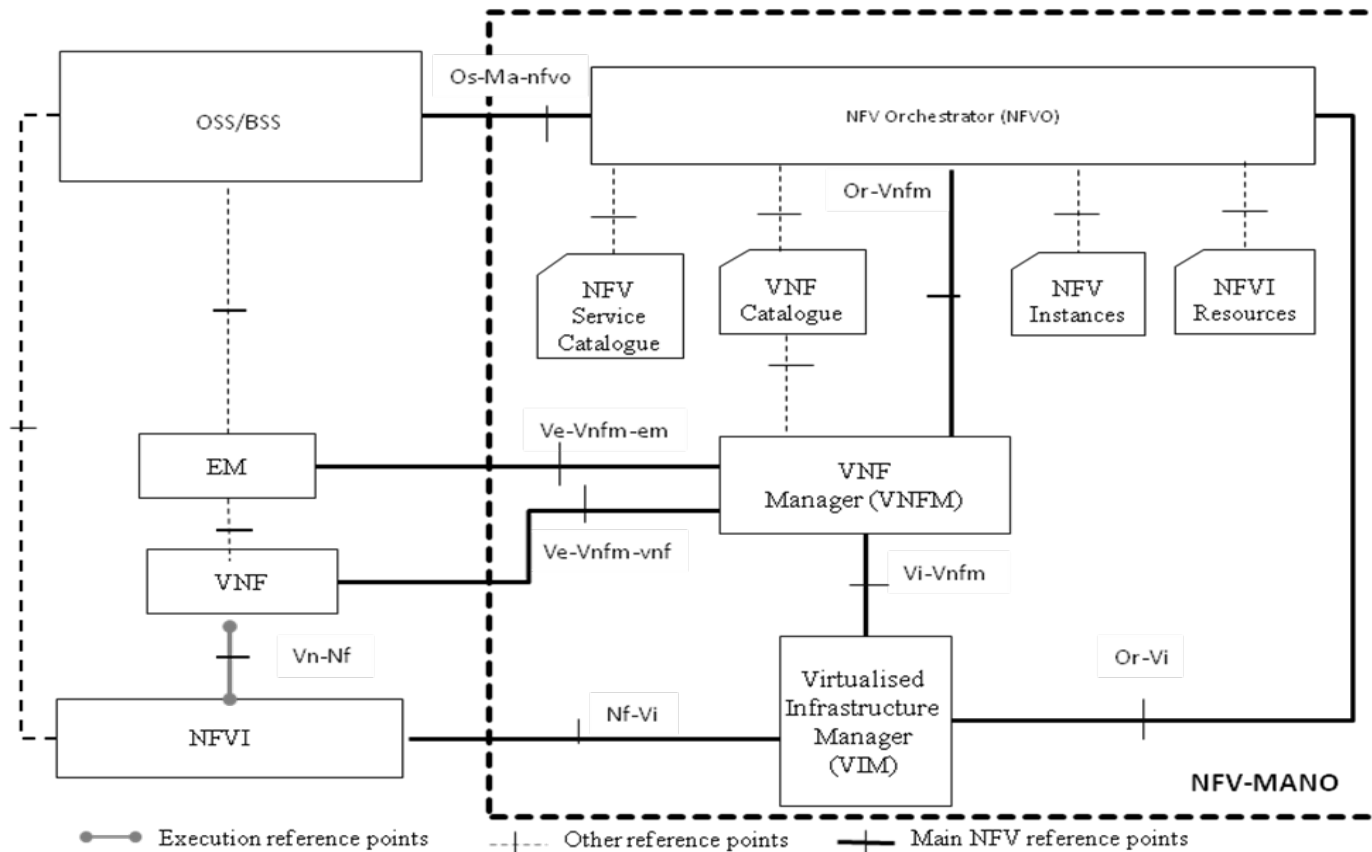

- **Os-Ma-nfvo**,
- **Ve-Vnfm-em**
- **Ve-Vnfm-vnf**
- **Nf-Vi**
- **Or-Vnfm**
- **Or-Vi**
- **Vi-Vnfm**

Multi domain Network Service Orchestrator / Resource Orchestrator

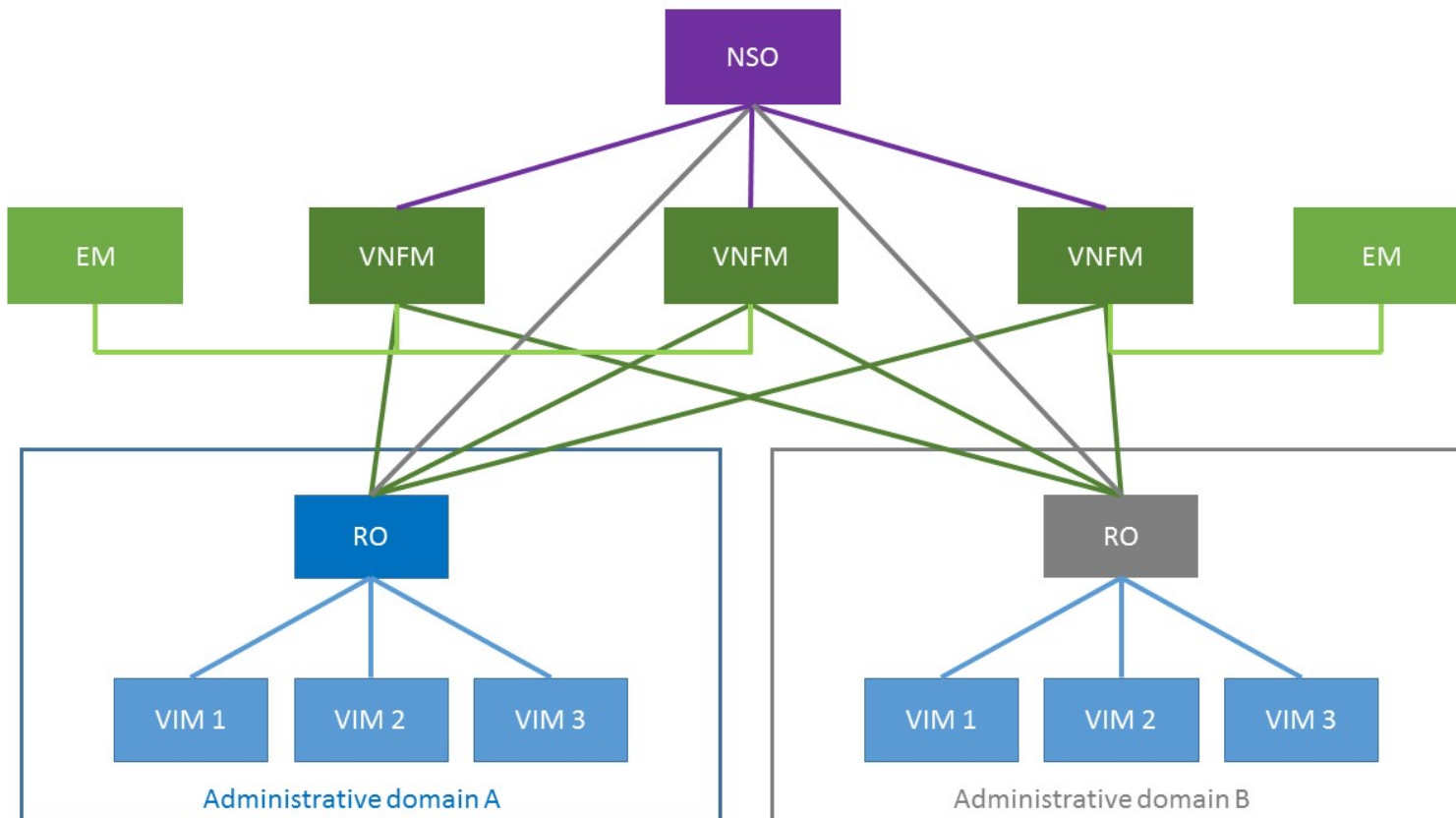

ETSI IFA 009

Multi domain– Service control and Virtual Network Platform control

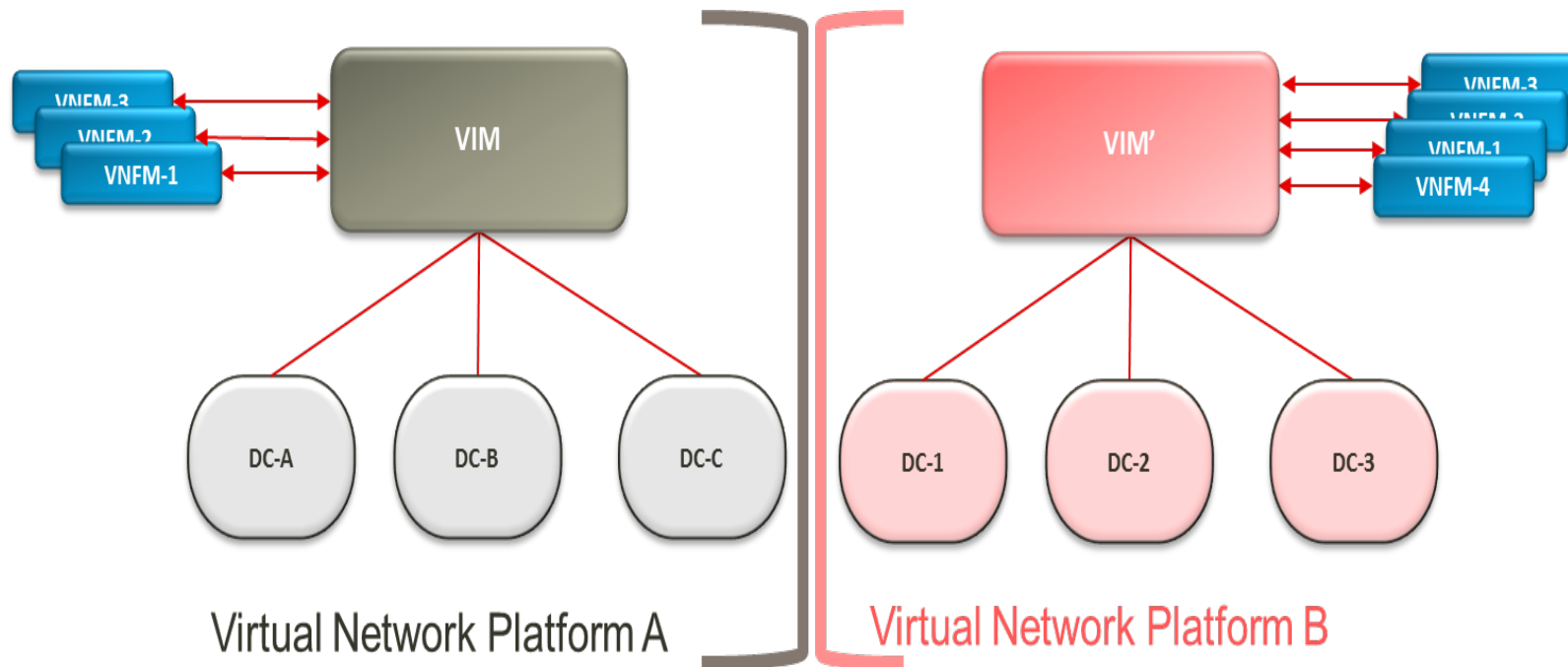

Multi domain - Network services offered by a separate admin domain

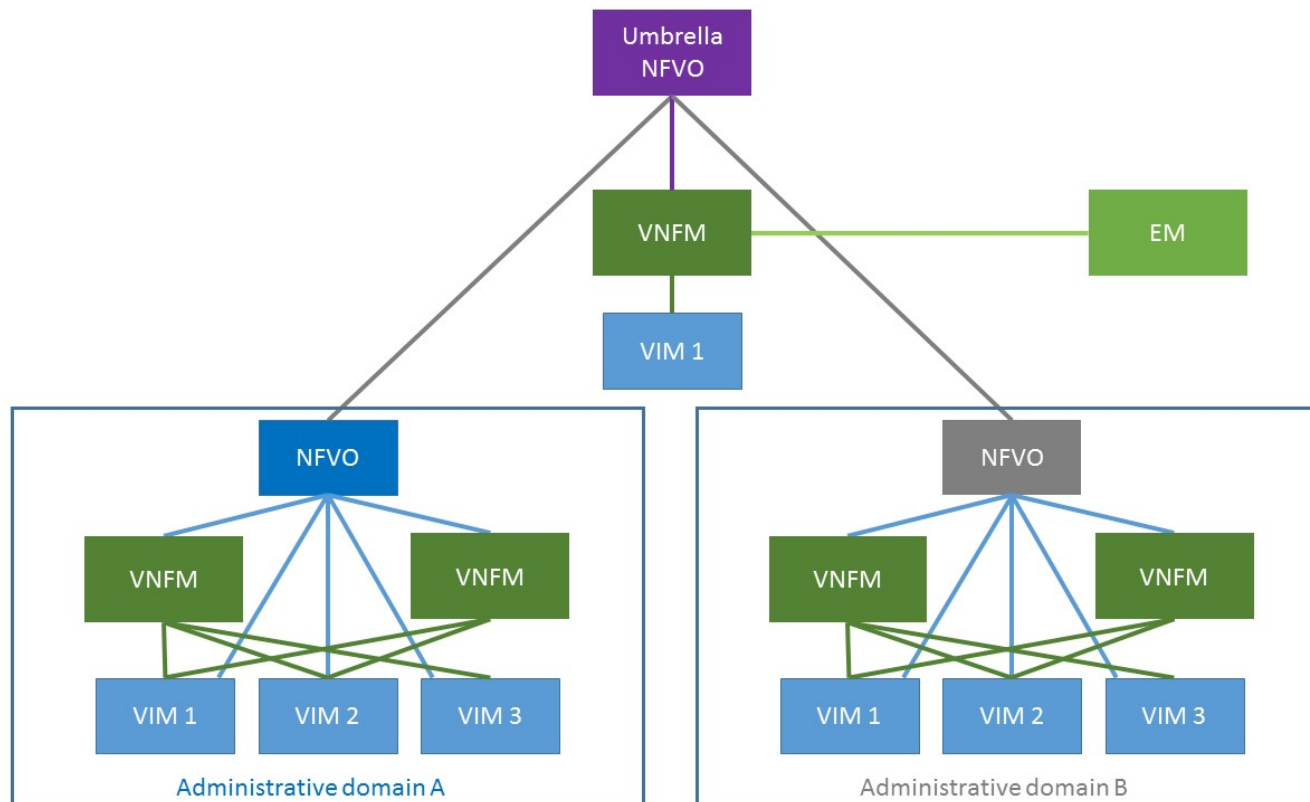

Contents List

1. Key Slicing concepts and history
2. Slicing Key Characteristics & Usage scenarios & Value Chain
3. Multi-Domain Network Function Virtualisation
4. Review of Research projects and results in network and cloud slicing
5. Open Source Orchestrators
6. Standard Organization activities: NGMN, ITU-T, ONF, 3GPP, ETSI, BBF, IETF
7. Industrial perspective on Network Slicing
8. Review of industry Use Cases
9. Network Slicing Challenges
10. Concluding remarks of Network Slicing
11. Acknowledgements & References

Review of Research projects and results in network and cloud slicing



EU Projects:

- SONATA
- 5GEX
- NECOS
- 5G TRANSFORMER
- 5G PAGODA
- 5G NORMA
- 5G SLICENET

5G SONATA– H2020 Project

Agile Service Development and Orchestration in 5G Virtualized Networks



SONATA High Level Architecture and Interfaces

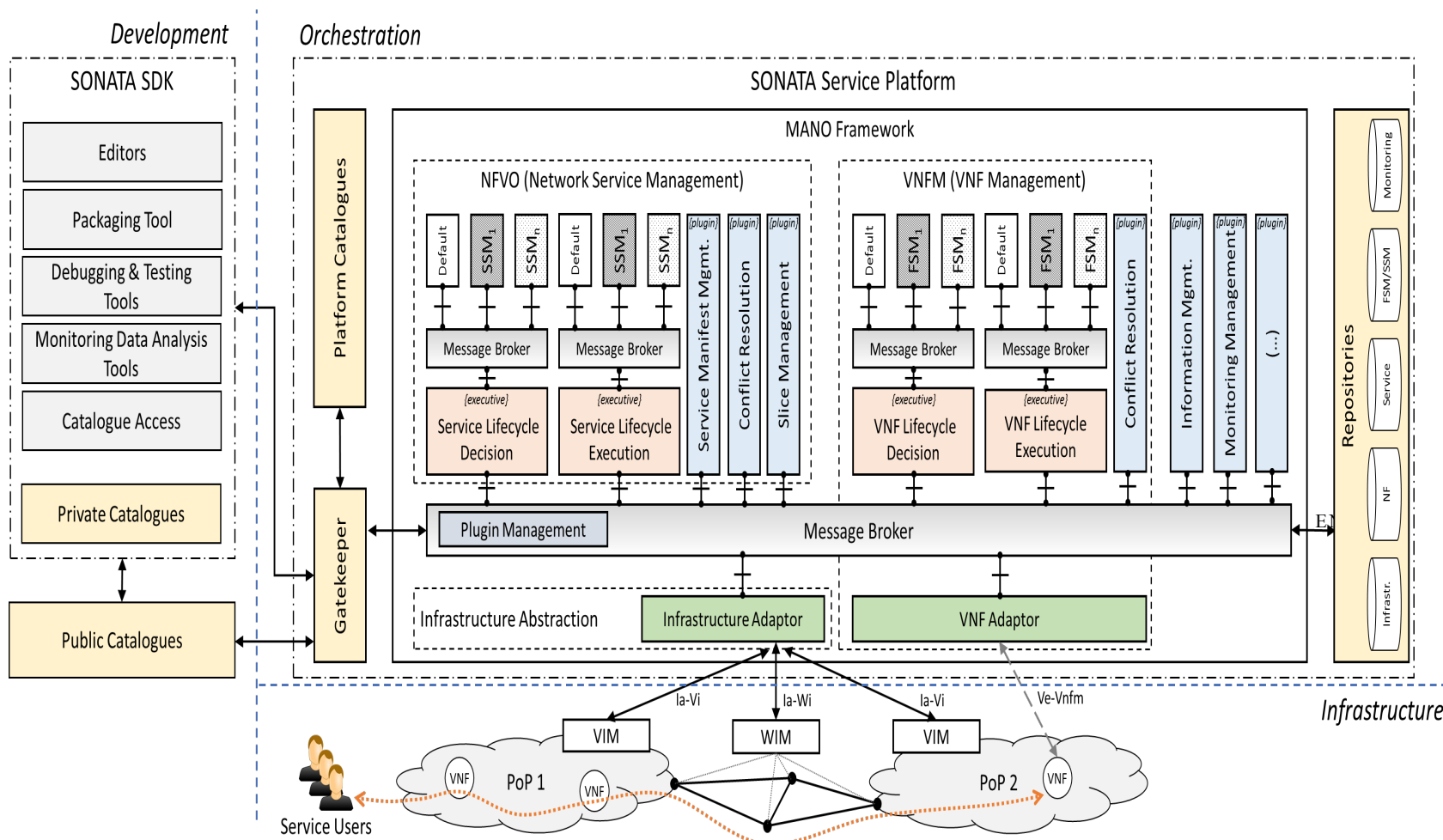

<http://sonata-nfv.eu>

Flexible programmability of software networks and the optimization of their deployments

5GEx– H2020 Project

Multi-Domain Network Service Orchestration

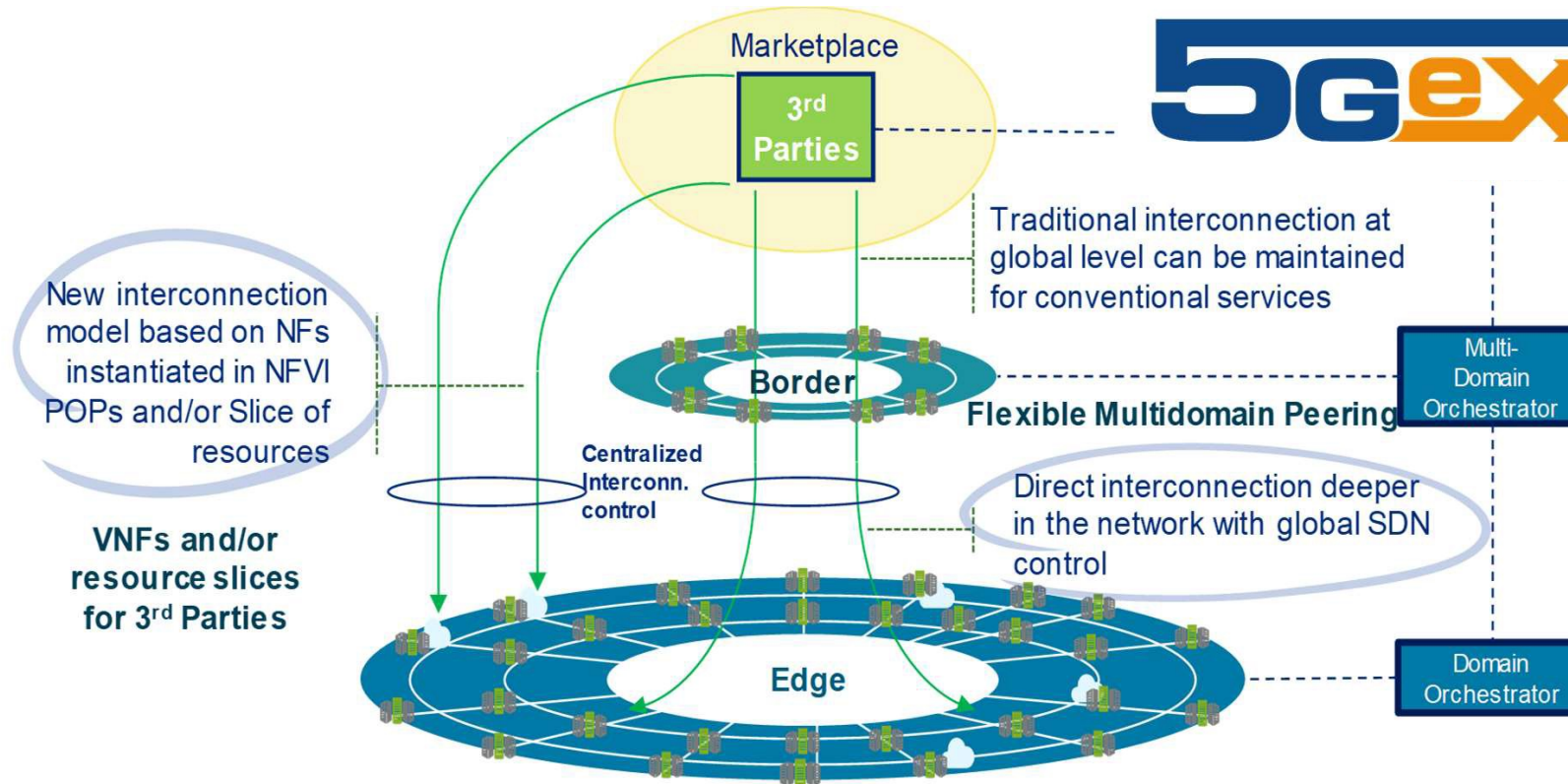

<http://www.5gex.eu/>
 From dedicated physical networks with dedicated control and dedicated services and resources for different applications to a “network factory” where resources and network functions are traded and provisioned – a new infrastructure and services “manufactured by SW”.

5GEx– H2020 Project

Multi-Domain Network Service Orchestration



5GEX High Level Architecture and Interfaces

5GEX Interface specification steps

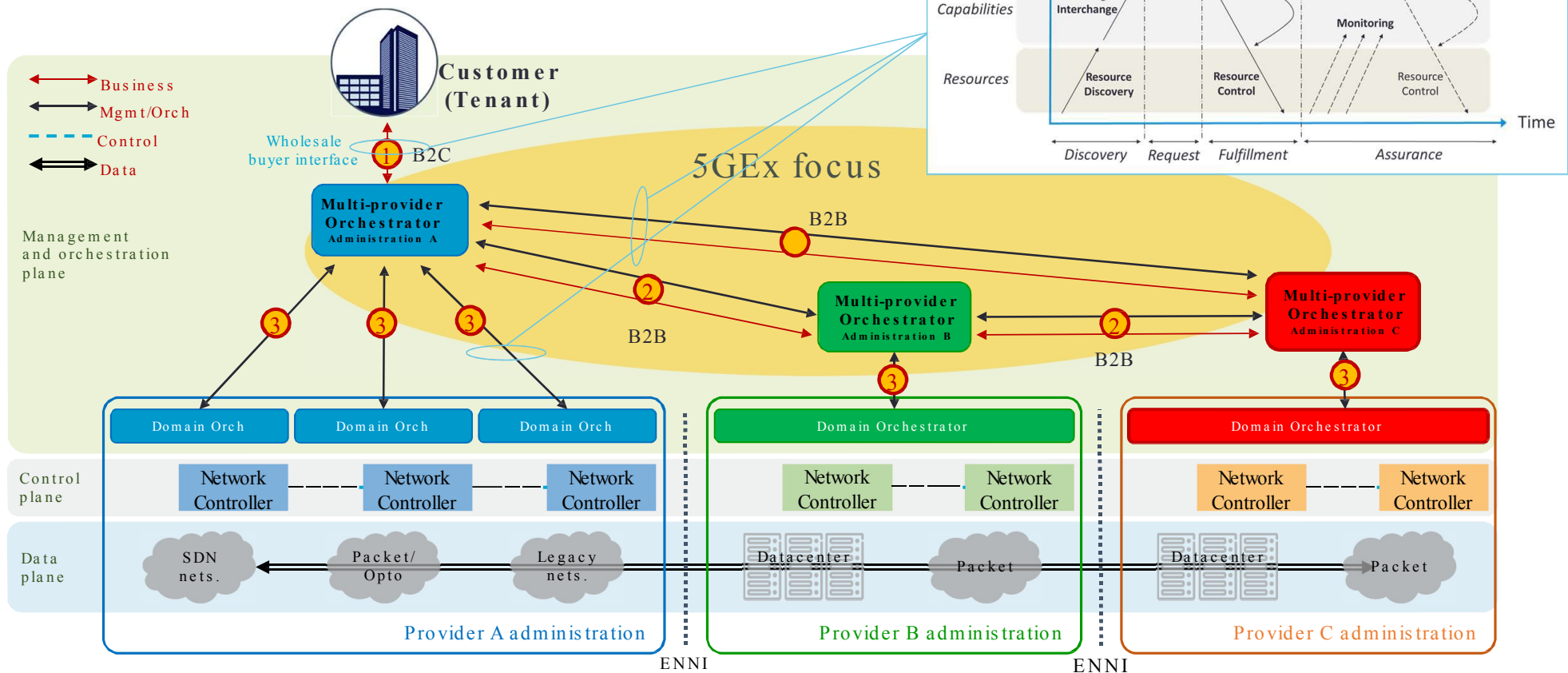

5GEx– H2020 Project

Multi-Domain Network Service Orchestration

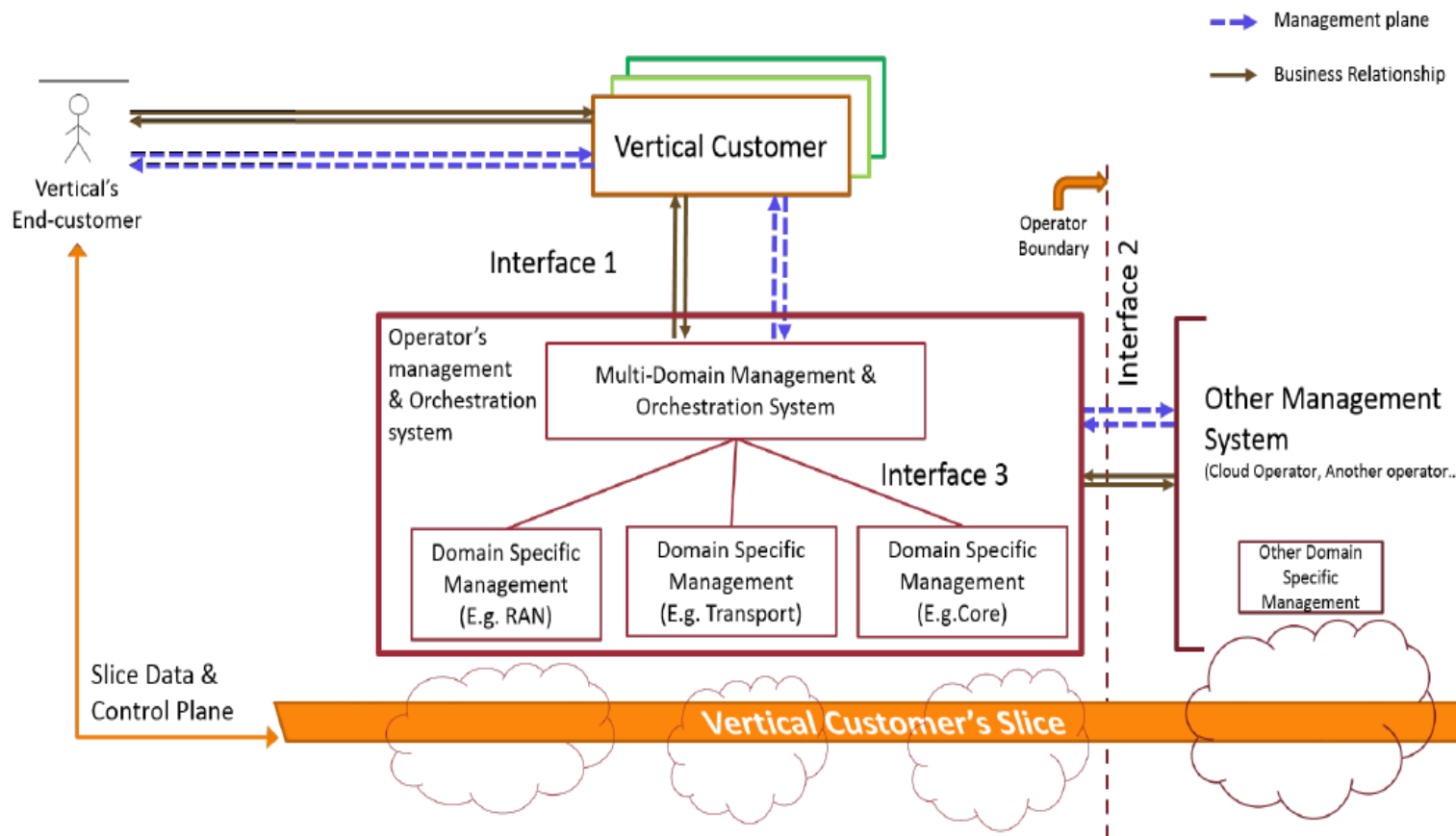

MdO - Multi-domain Orchestrator -

I1 - MdO exposes service specification APIs (Customer-to-Business, C2B) allowing business customers/Tenants to specify their requirements for a given service.

I2 - MdO interacts with peer MdOs.

I3 - APIs to orchestrate resources and services within the same administrative domains

5GEX & SONATA– H2020 Projects

Hierarchical Service Provider & Multi-Mano Interaction

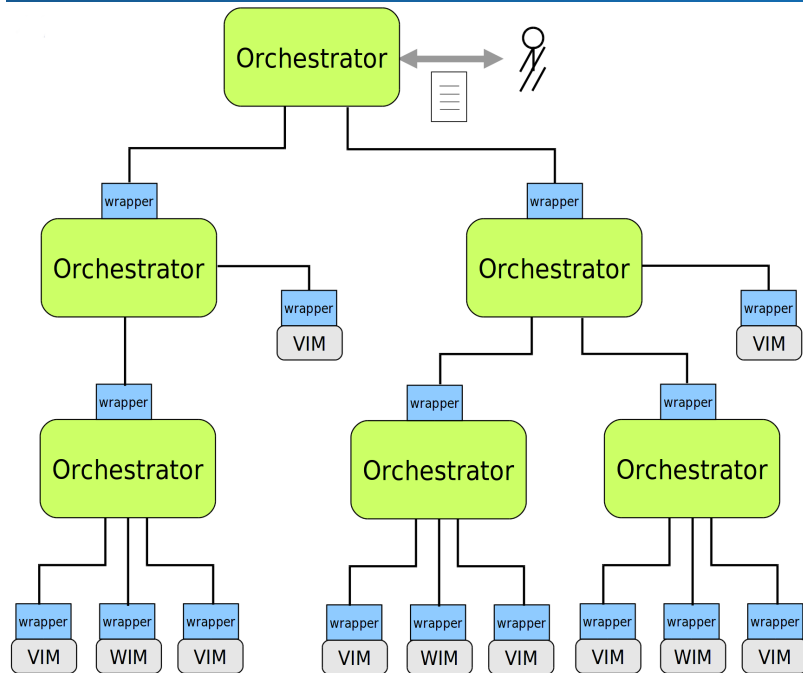

Hierarchical Service Provider & Multi-Mano Interaction – UCL developed Open Source Solutions:

<http://clayfour.ee.ucl.ac.uk/5g-integration/index.html#part8>

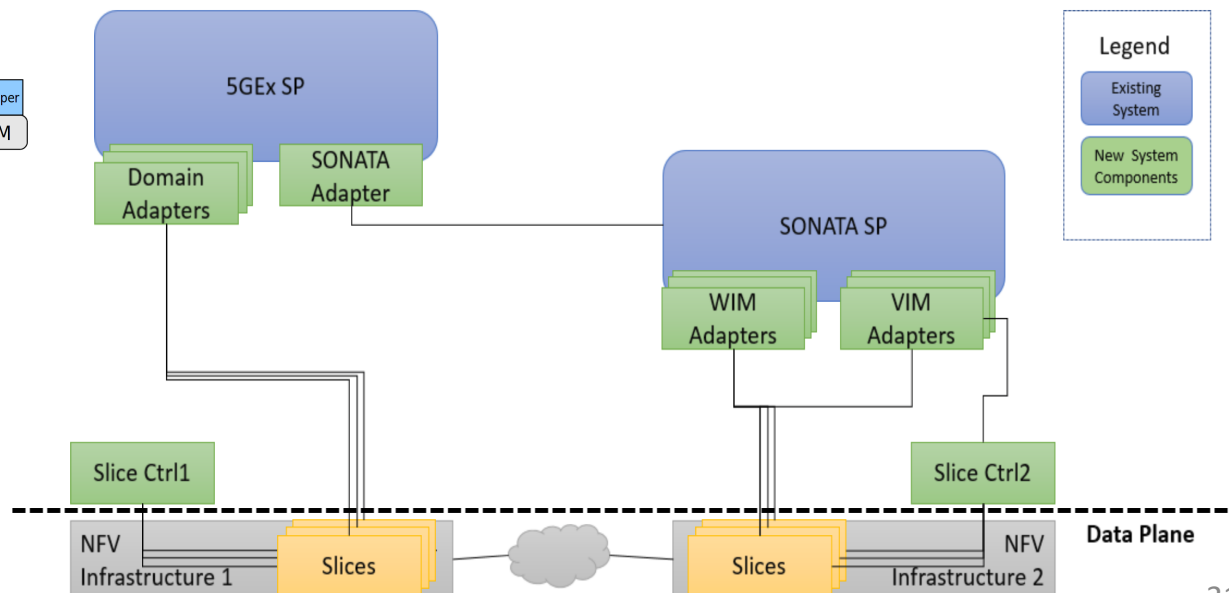

NECOS– H2020 Project

Novel Enablers for Cloud Slicing



NECOS High Level Architecture and Interfaces

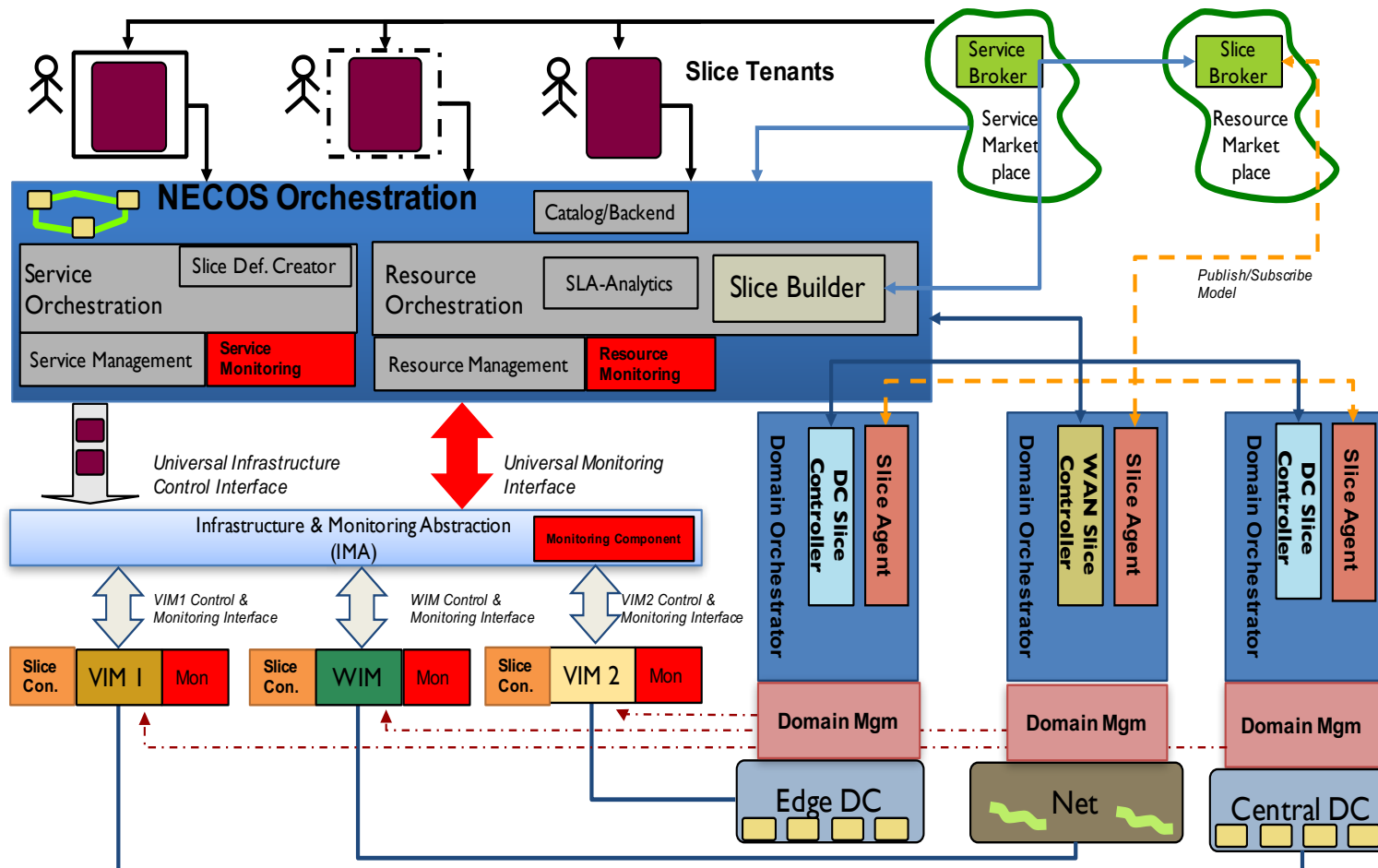

<http://www.h2020-necos.eu>

Development of a lightweight system for enabling cloud networking slicing capabilities in multi-domain scenarios (native integration of cloud computing and advanced networking).

NECOS– H2020 Project

Novel Enablers for Cloud Slicing



Slicing Models

<http://www.h2020-necos.eu>

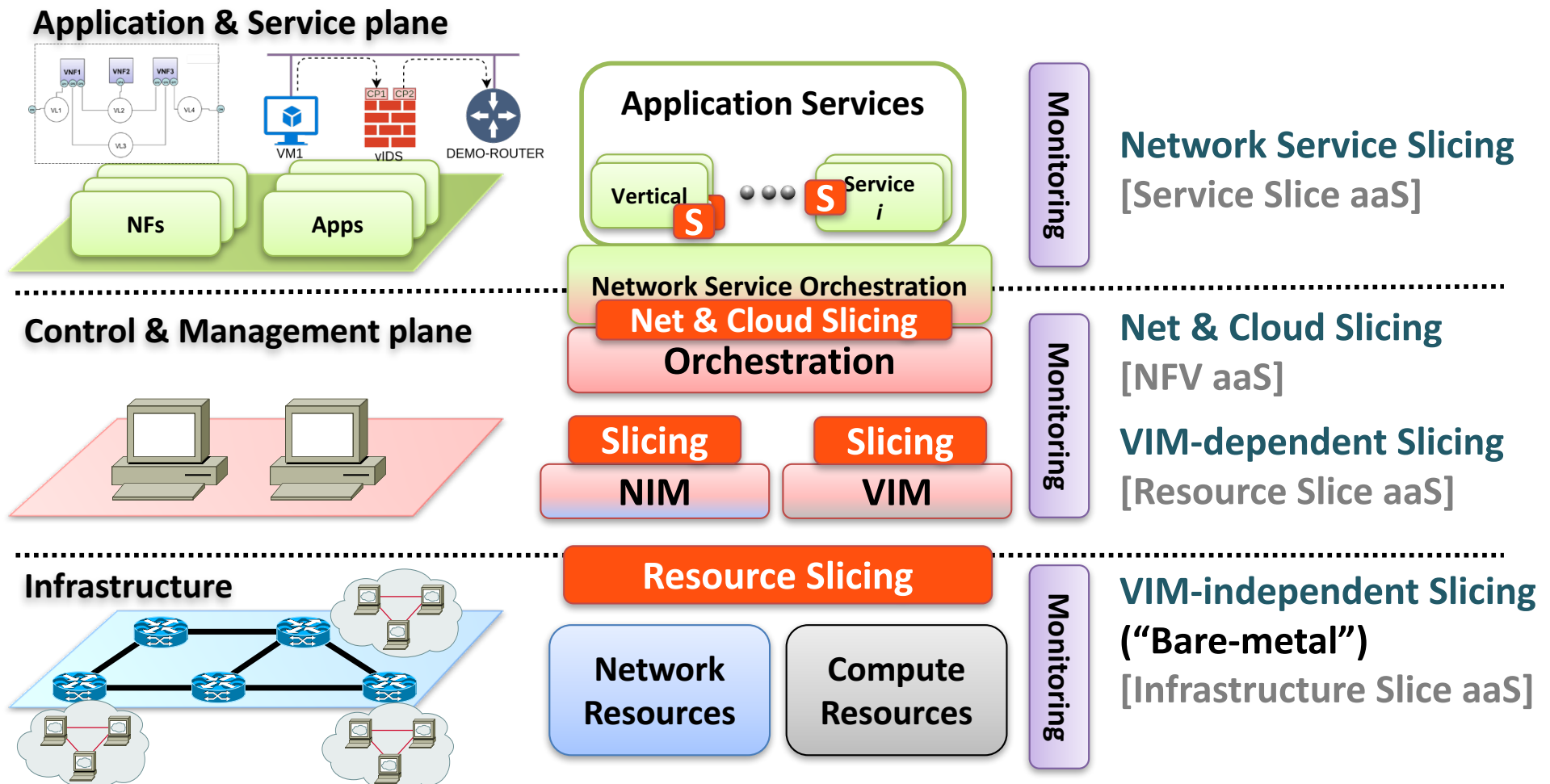

NECOS– H2020 Project

Novel Enablers for Cloud Slicing



NECOS Cloud Slicing Realisation – NFVi slicing with VIM on demand (UCL)

Open Source Slice Controller - Developed at UCL

<http://clayfour.ee.ucl.ac.uk/slice/index.html>

- a Slice Manager — which is composed of a Resource Manager manages all of the resources in the DC and keeps a track of which resources have been allocated to which slice and a User Manager that manages all of the users that can access the Slice Controller.
- a Slice Information Store — which database lists all of the slices and all of the resources in the slice, together with meta-data such as the VIM REST entry point, and the keys used for access to all the resources.
- a Slice Creator — which is responsible for handling requests for slices and interacting with the Resource Manager and the User Manager to determine if it is possible to create a new slice. If the slice creation is possible it interacts with the VIM Factory.
- the VIM Factory — which is able to allocate a VIM of a particular type, and configure it to use the resources which have been picked by the Slice Creator. Once the VIM is allocated and deployed, the REST entry point is returned to the caller.
- the VIM Placement Manager — which is responsible for determining which host should be used to execute a newly created VIM.

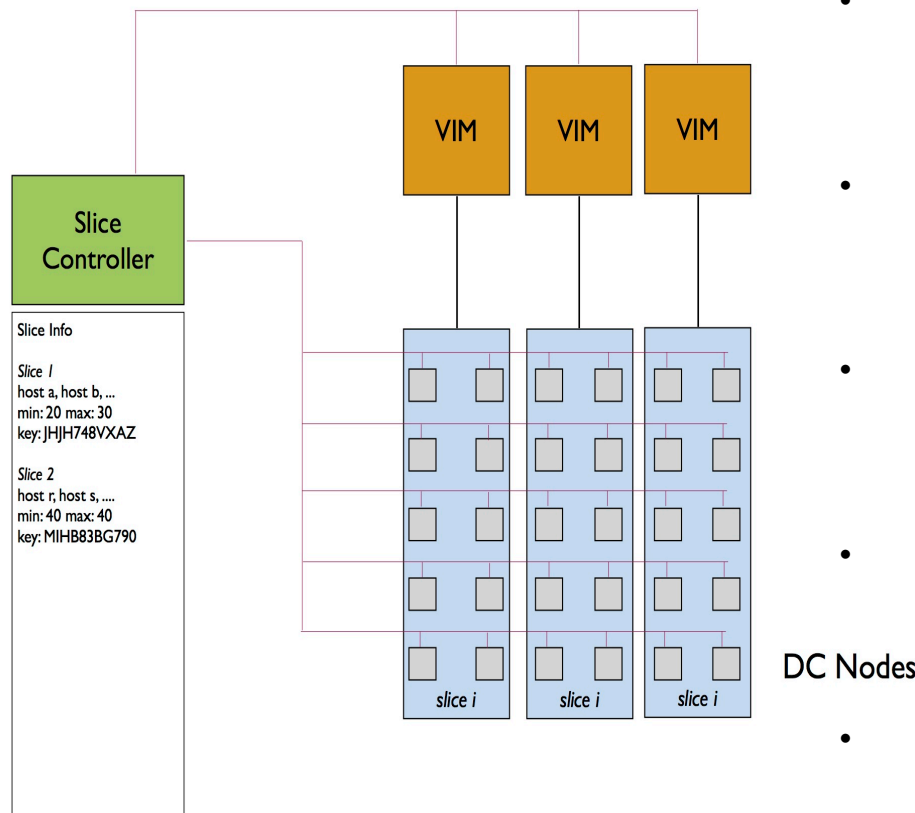

5G NORMA – H2020 Project

Novel Radio Multiservice adaptive network Architecture for 5G networks



5G NOMA – High Level Architecture (functional view)

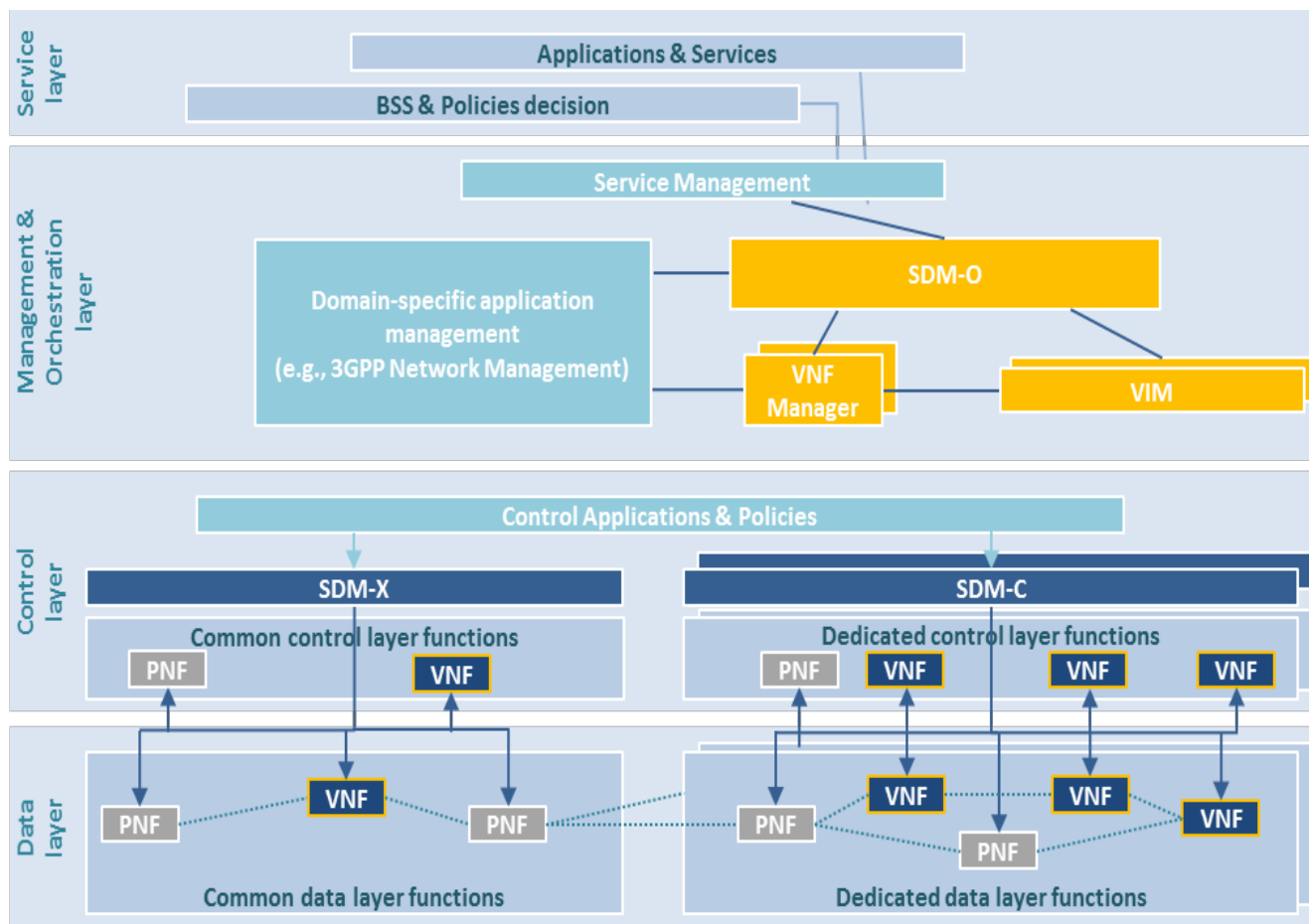

<http://www.it.uc3m.es/wnl/5gnorma/>

- 1) Adaptive (de)composition and allocation of NFs Joint
- 2) Optimization of RAN and Core Network
- 3) SW-defined Mobile Control

Exposure of control

- Service management
- Mapping of customer-facing services and procedures to resource-facing services and procedures
- Access control and integrity

Network slicing

- SDM-O: Service and Resource
- Orchestration
- Inter-slice and intra-slice

Network programmability

- Differentiation into common and dedicated functions
- SDM-X and SDM-C

5G TRANSFORMER – H2020 Project

5G Platform for Vertical Actors

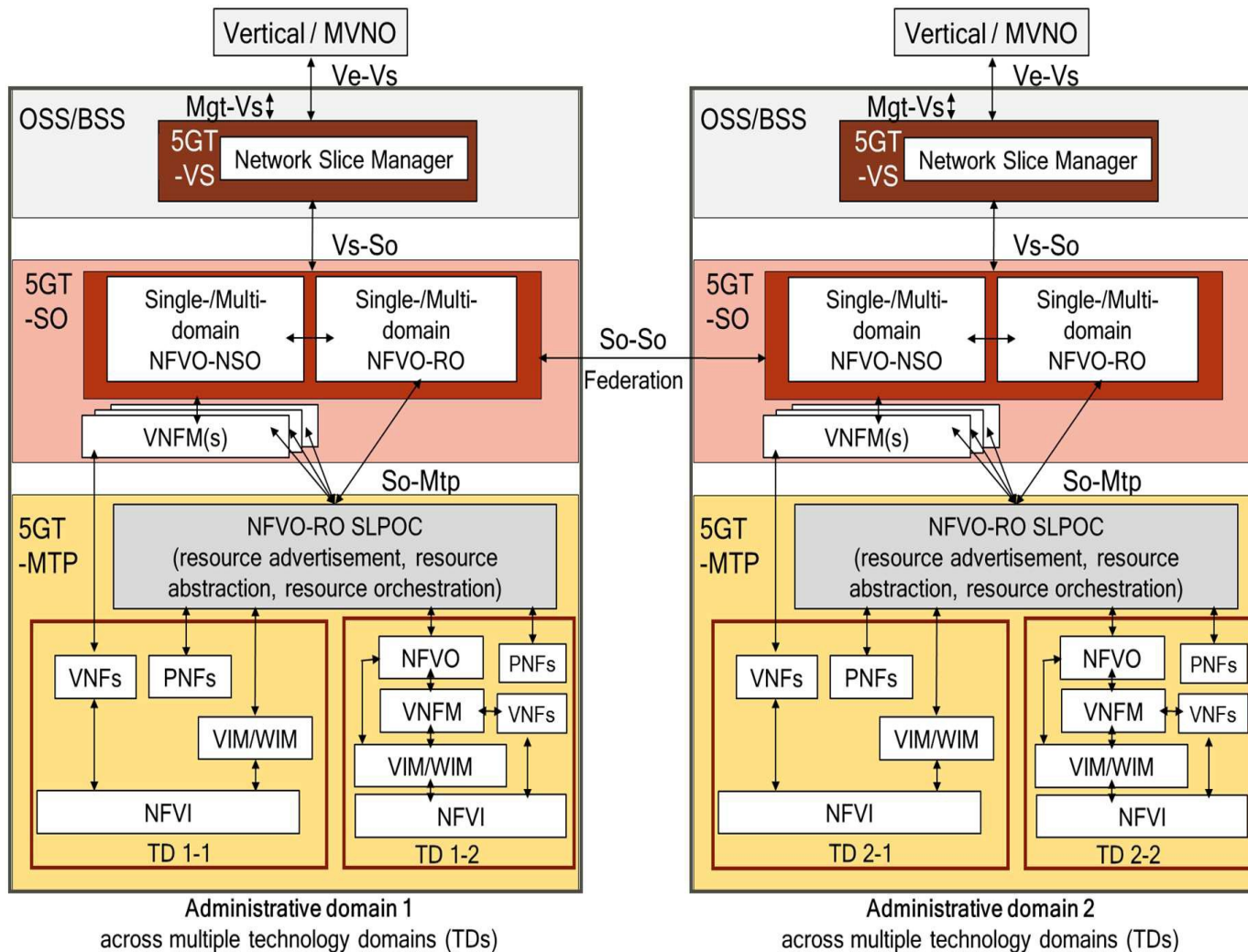

<http://5g-transformer.eu>

- 1) Vertical Slicer as the logical entry point for verticals to support the creation of their respective transport slices
- 2) Service Orchestrator to orchestrate the federation of transport networking and computing resources from multiple domains and manage their allocation to slices.
- (3) Mobile Transport and Computing Platform for integrated fronthaul and backhaul networks.

5G PAGODA – H2020 Project

A network slice for every service!



5G PAGODA – High Level Architecture <https://5g-pagoda.aalto.fi>

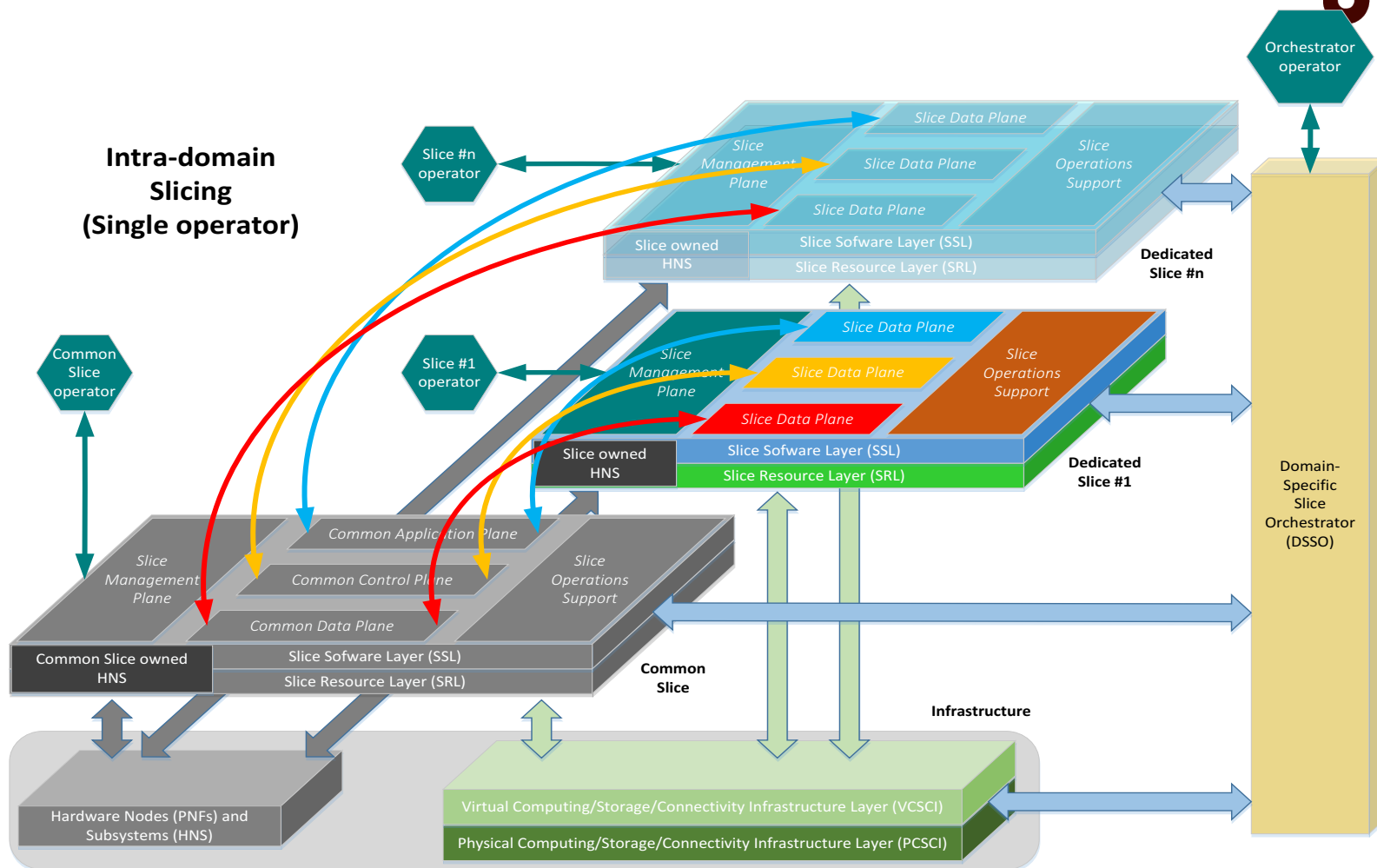

5G PAGODA – H2020 Project

A network slice for every service!



5G PAGODA – High Level Slicing Architecture

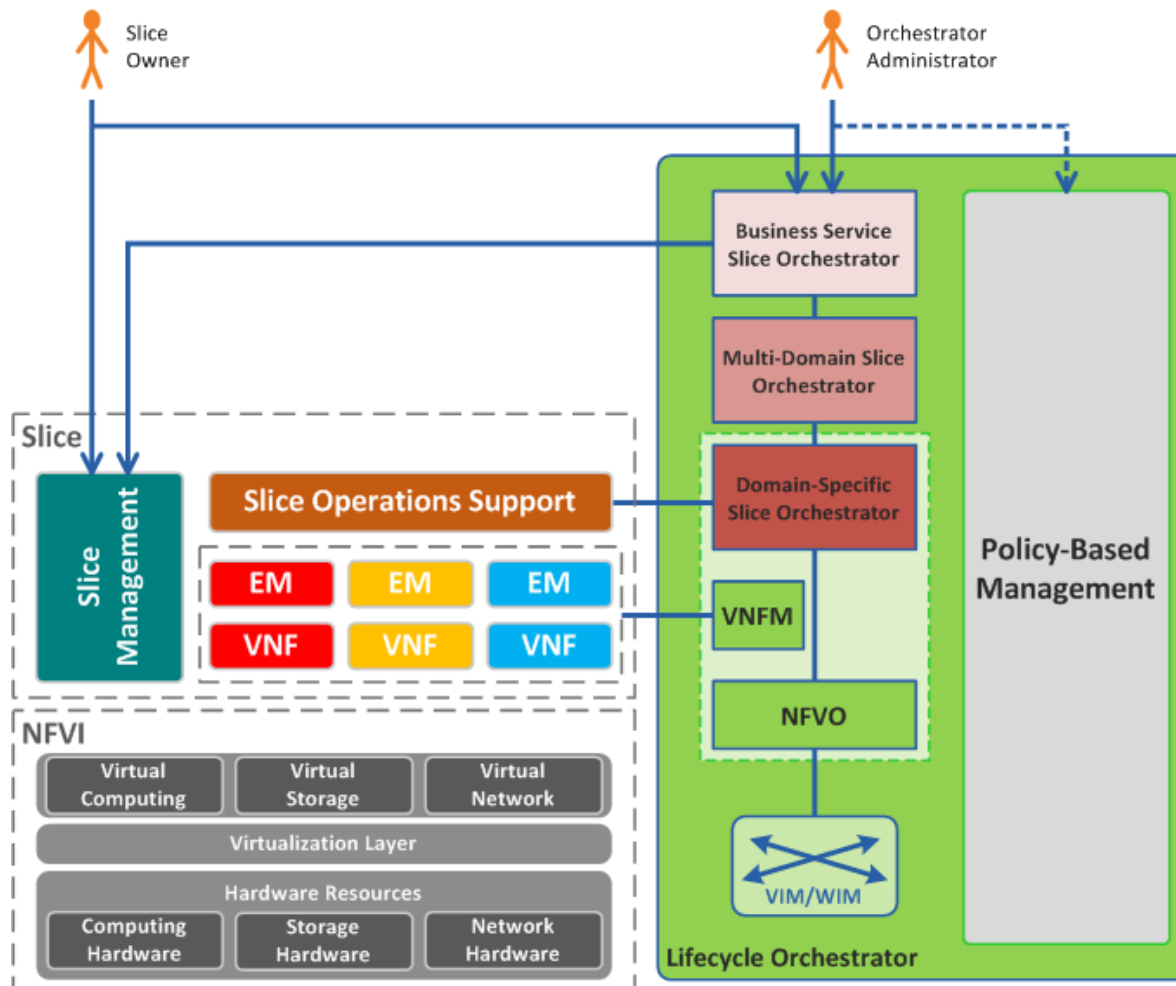

<https://5g-pagoda.aalto.fi>

1. scalable 5G slicing architecture,
2. extending the current NFV architecture towards support of different specialized network slices composed of multi-vendor virtualized network functions scalable 5G slicing architecture,
3. extending the current NFV architecture towards support of different specialized network slices composed of multi-vendor virtualized network functions

5G SLICENET – H2020 Project



5G SLICENET – High Level Slicing Architecture



<https://slicenet.eu>

1. End-to-End Cognitive Network Slicing and
2. Slice Management Framework in Virtualised Multi-Domain, Multi-Tenant 5G Networks

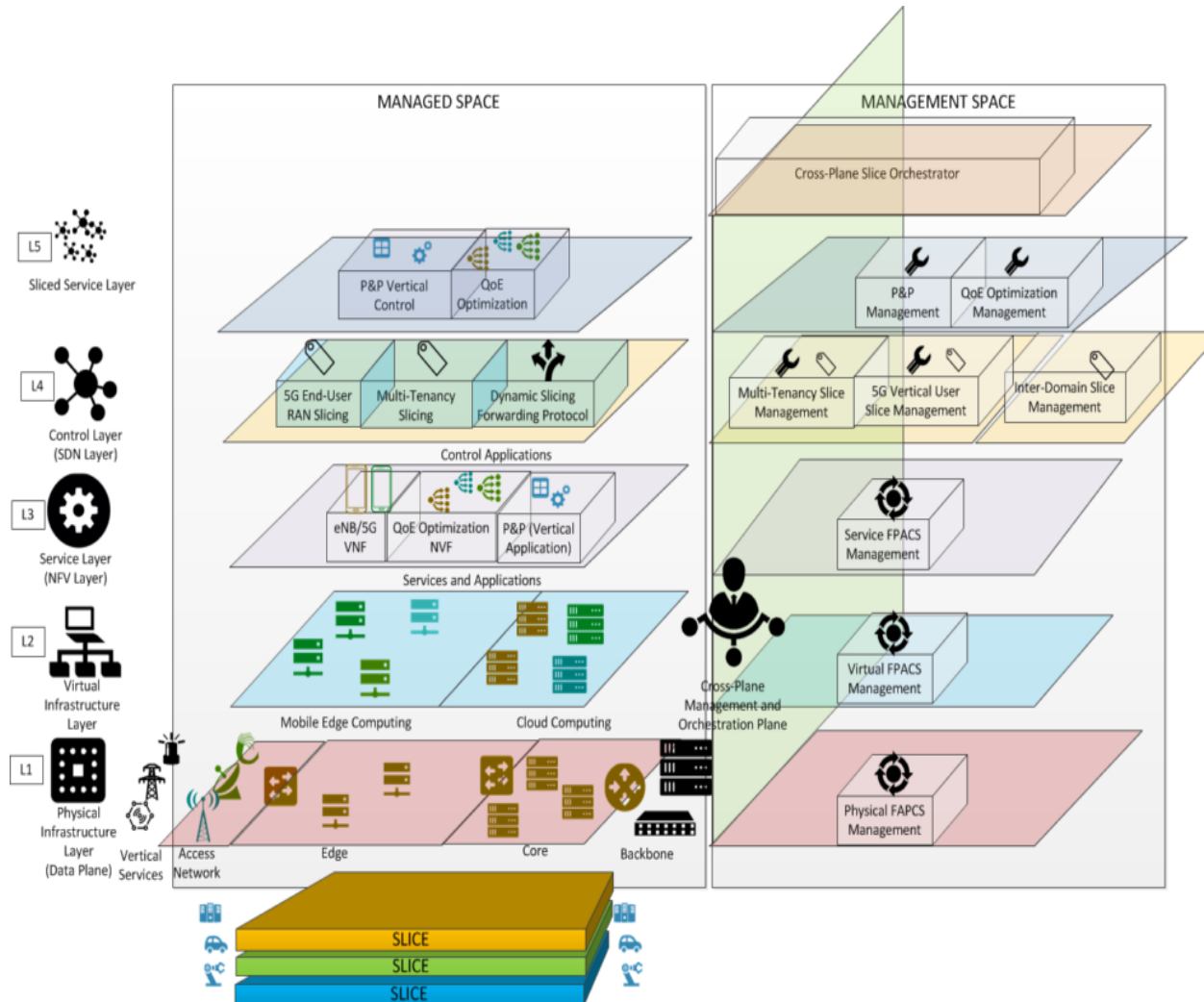

Open Source Orchestrators & Frameworks

1. OSM - “Open Source MANO” Available: <https://osm.etsi.org/>
2. ONAP-“Open Network Automation Platform,” Available: <https://www.onap.org/>
3. Claudify- GigaSpaces, Available: <http://cloudify.co/>
4. ESCAPE “ Extensible Service ChAin Prototyping Environment” EU project UNIFY “Unifying Cloud and Carrier Networks,” Available: <http://www.fp7-unify.eu/>
5. Open Baton- Fraunhofer and T. Berlin, Available: <http://openbaton.github.io/>
6. TeNOR- micro-service based NFV orchestration platform – T-NOVA EU project “Network Functions as a Service over Virtualised Infrastructures.” Available <http://www.t-nova.eu/>
7. XOS -“A Service Abstract Layer for CORD,” Available: <http://xos.wpengine.com/>
8. SONATA – H2020 Project ““SONATA NFV,” Available: <http://www.sonata-nfv.eu>
9. 5GEX H2020 Project “Multi-domain Resource Orchestration” Available: <http://www.5gex.eu/>
10. VLSP “Very Lightweight Network & Service Platform” University College London Available: <http://clayfour.ee.ucl.ac.uk/usr/index.html>
11. NECOS- H2020 Project “Novel Enablers for Cloud Slicing”; <http://www.h2020-necos.eu>

Contents List

1. Key Slicing concepts and history
2. Slicing Key Characteristics & Usage scenarios & Value Chain
3. Multi-Domain Network Function Virtualisation
4. Review of Research projects and results in network and cloud slicing
5. Open Source Orchestrators
6. Standard Organization activities: NGMN, ITU-T, ONF, 3GPP, ETSI, BBF, IETF
7. Industrial perspective on Network Slicing
8. Review of industry Use Cases
9. Network Slicing Challenges
10. Concluding remarks of Network Slicing
11. Acknowledgements & References

NGMN- Next Generation Mobile Networks

NGMN

- 5G White paper- it Introduces network slicing, named as 5G slicing in 5G white paper, for purposes of flexibility, management and orchestration- <https://www.ngmn.org/5g-white-paper/5g-white-paper.html>
- White Paper - description of network for service provider networks https://www.ngmn.org/fileadmin/user_upload/161010_NGMN_Network_Slicing_framework_v1.0.8.pdf

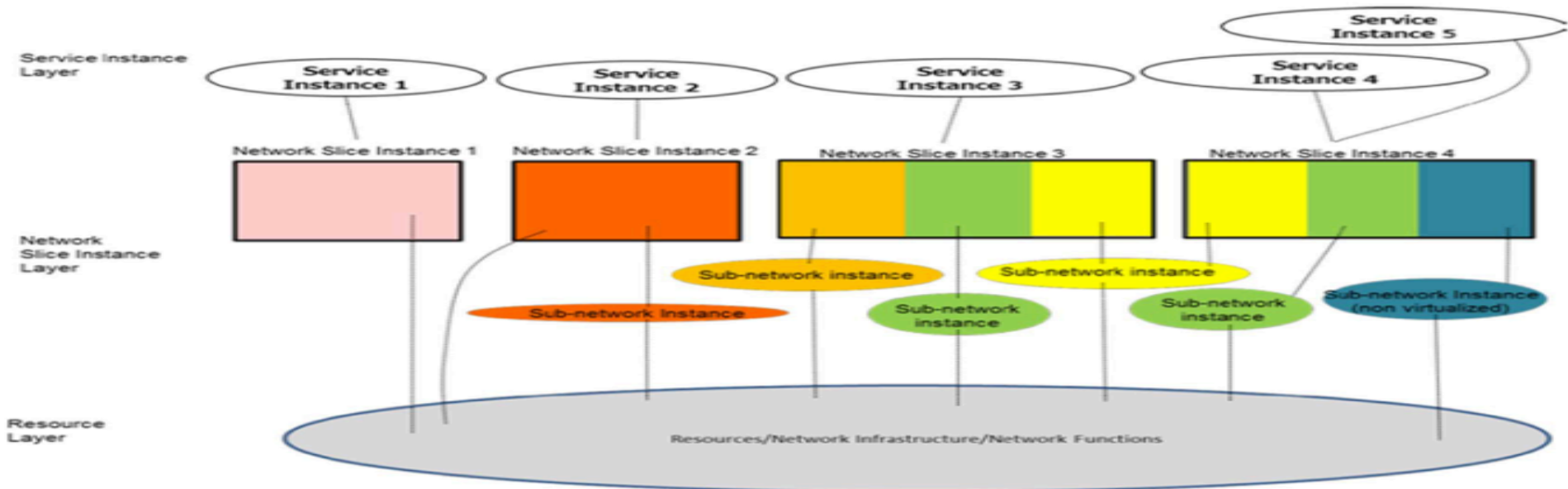

NGMN Network slice conceptual outline

ITU-T IMT2020 Framework

ITU-T IMT2010/ SG13 - <http://www.itu.int/en/ITU-T/focusgroups/imt-2020/Pages/default.aspx>

- Recommendation: Application of network softwarization to IMT-2020 (O-041) – 150 pp
- Framework for IMT-2020 overall network architecture (O-043)
- Network management framework for IMT-2020 (O-047)
- IMT-2020 network management requirements (O-046)

ITU-T IMT 2020 Framework Characteristics:

- **Architecture to support diverse service requirements**
 - *End-to-end network slicing to provide dedicated logical networks with customer (or service) specific functionality; network capability exposure*
 - *Softwarization everywhere leveraging existing tools such as SDN and NFV*
 - **Different mobility and diverse end-to-end QoS (data rate, reliability, latency etc.) requirements**
 - **Edge cloud support (MEC), distributed content and services**
- **Multiple access technologies (IMT-2020, IMT, WiFi, and fixed networks) with access agnostic common core network**
- **Separation of control plane (CP) and user plane (UP) functions, allowing independent scalability and evolution**
- **Distributed flat network allowing flexible deployment of CP/UP functions**
 - **Converged data plane functions (IP flow management, Multi-RAT coordination, etc.)**
 - **Unified control functions (e.g. authentication) at the core with some functions at the edge**
 - **Modular function design to enable flexible network (e.g. separation of MM and SM)**

ITU-T IMT2020 Slicing Representation (II)

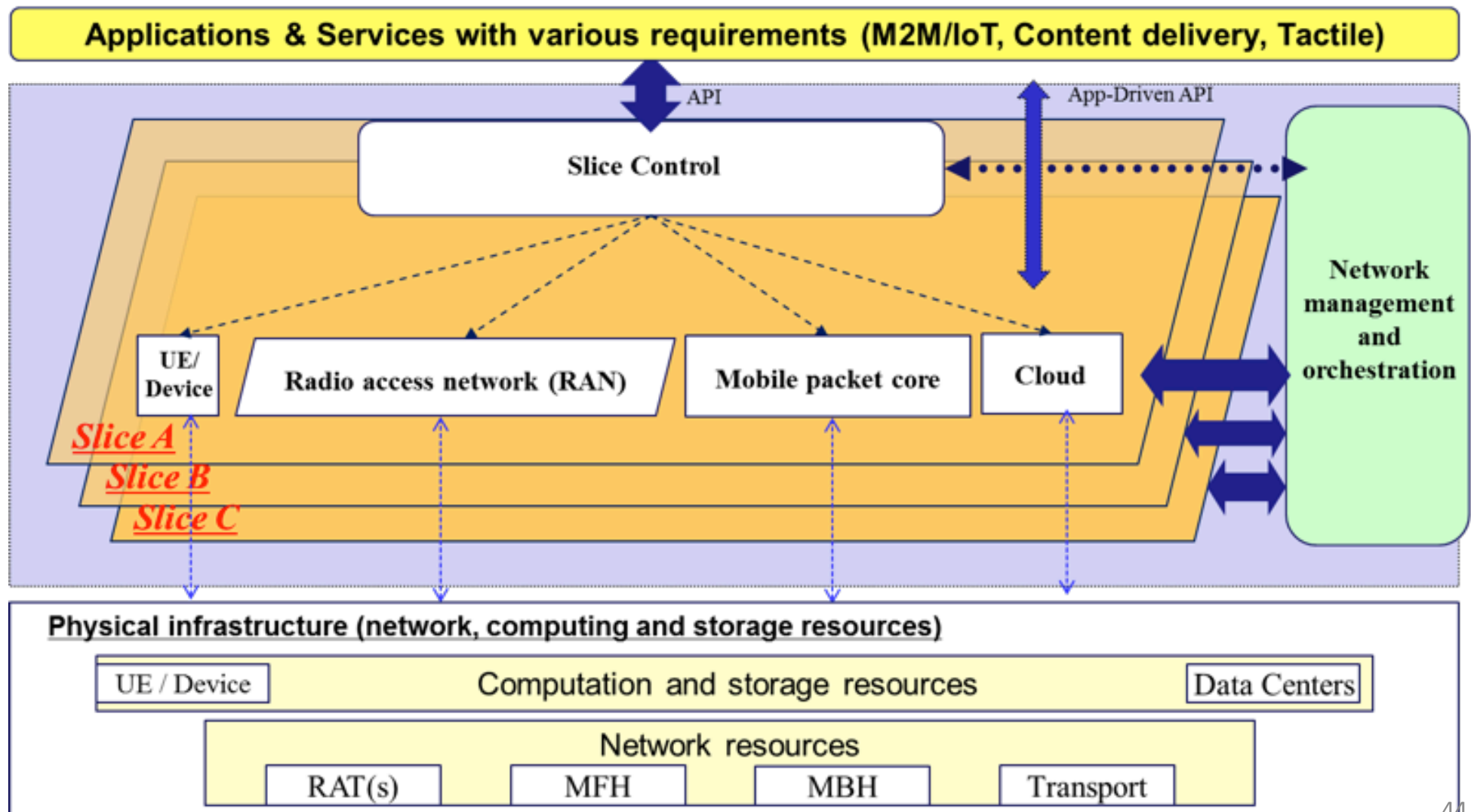

ITU-T SG13 and network slices

- Original work started in 2011-12 (LINP).
- IMT-2020 Framework focus on softwarization
 - Y.3110/3111: IMT-2020 network management and orchestration requirements & framework
 - **Vertical (service to network resources) and Horizontal slicing (concatenation of slices).**
 - **Independent management of each plane (service, control data)**
 - Y.3112: Framework for the support of Multiple Network Slicing
 - **Association of a user with multiple type of slices. Very closely coupled with 3GPP work.**
 - Y.3150 : High-level technical characteristics of network softwarization for IMT-2020
 - **Coordination with SDN and NFV technologies.**
 - **Data plane programmability – allow tenants of slices to provide top-design**
 - **tight integration data plane (network processing behavior).**

ITU-T IMT2020 Slicing Architecture (V)

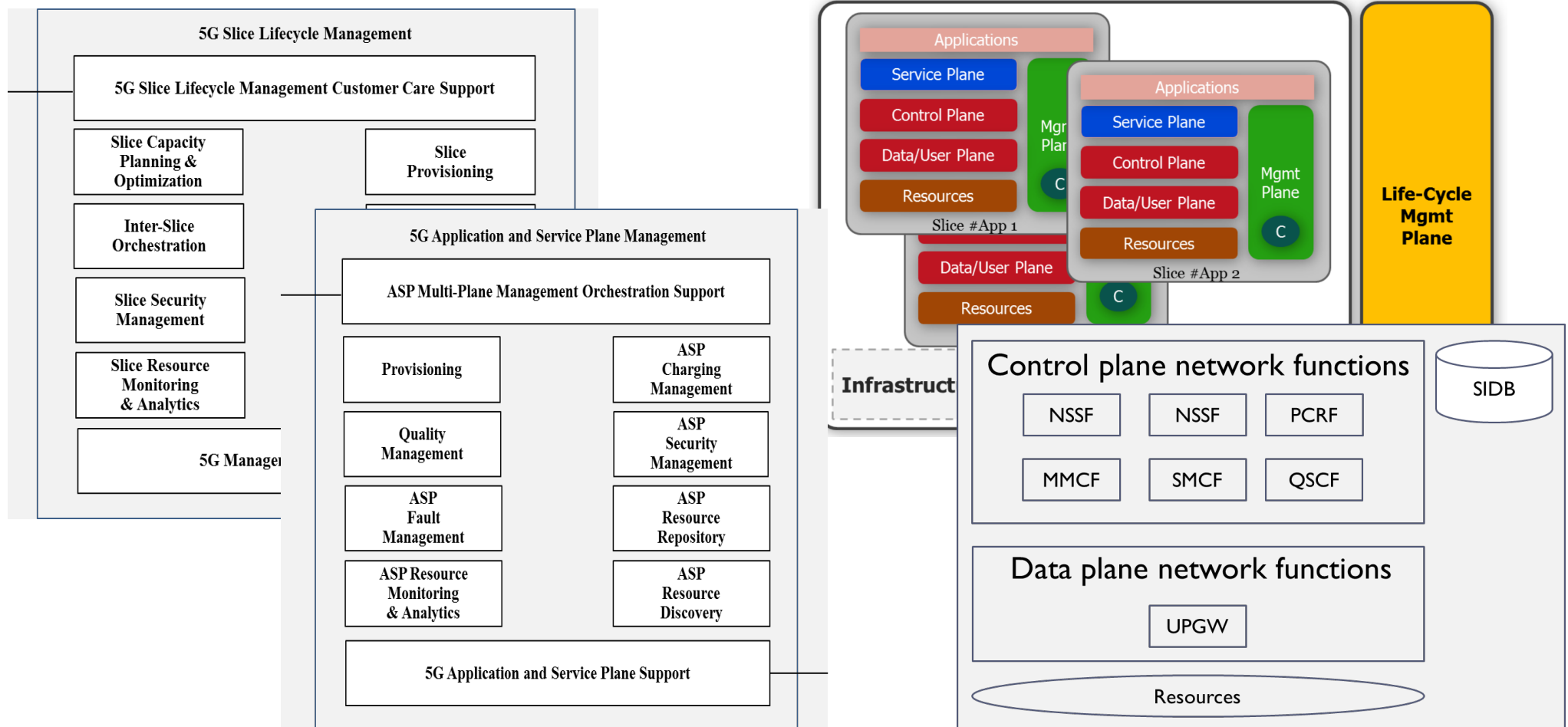

IMT-2020 Architecture Diagrams

ITU-T SG 15 – Q11/Q12 Proposed Slicing Packet Network



- **High BW scalability with multiple Ethernet PHY/WDM lambda λ bonding:** BW scalability with tools such as MLG multi-lane or FlexE multi-PHY bonding mechanism.
- **Simple switching mechanism to achieve low latency and low delay variation of end-to-end service:** Support deterministic low latency cross connect without the complexity of reading the label/address per packet, without packet buffer queuing, minimal forwarding table lookup,.
- **Nested Hard isolation Slicing:** Support nested network slicing as a key enabler for network slicing as a service and network slicing wholesaling.
- **Support Multi service:** Appropriate Multi service support should be considered. The network should support all kinds of services in Metro network such as Wireless backhaul, Enterprise e-Line/e-LAN, residential broadband.
- **High accuracy timing synchronization:** High accuracy timing synchronization better than +/- 130ns for 5G wireless.

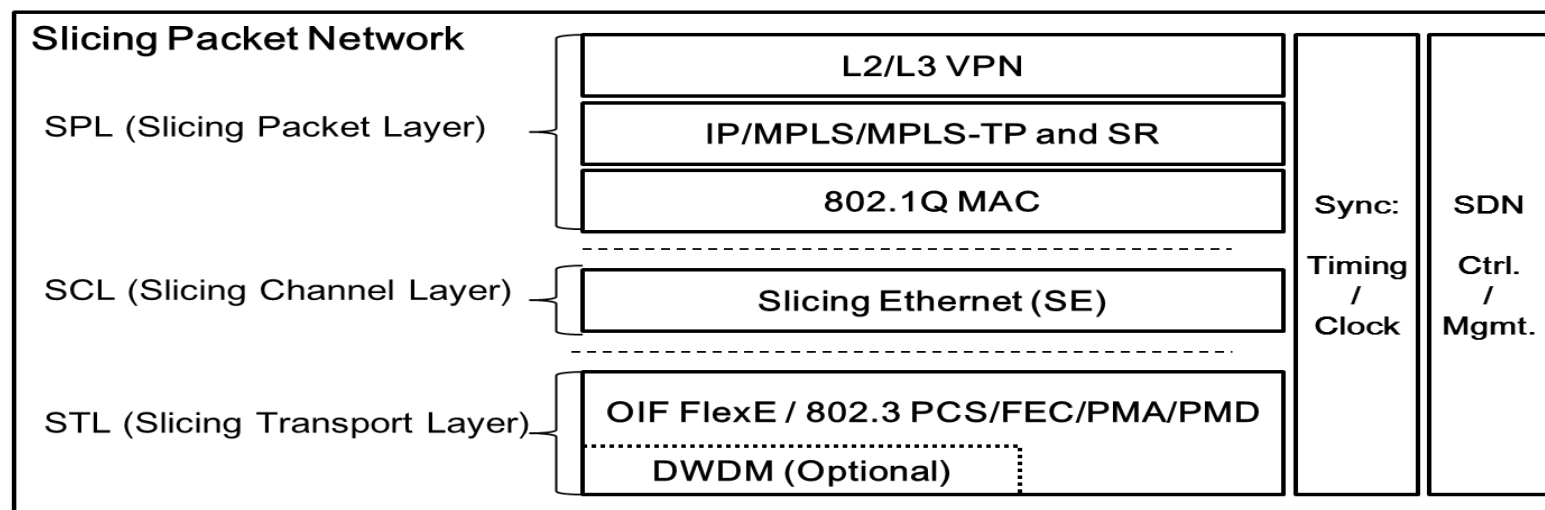

ITU-T IMT2020 (I)

IMT-2020 slice life-cycle management

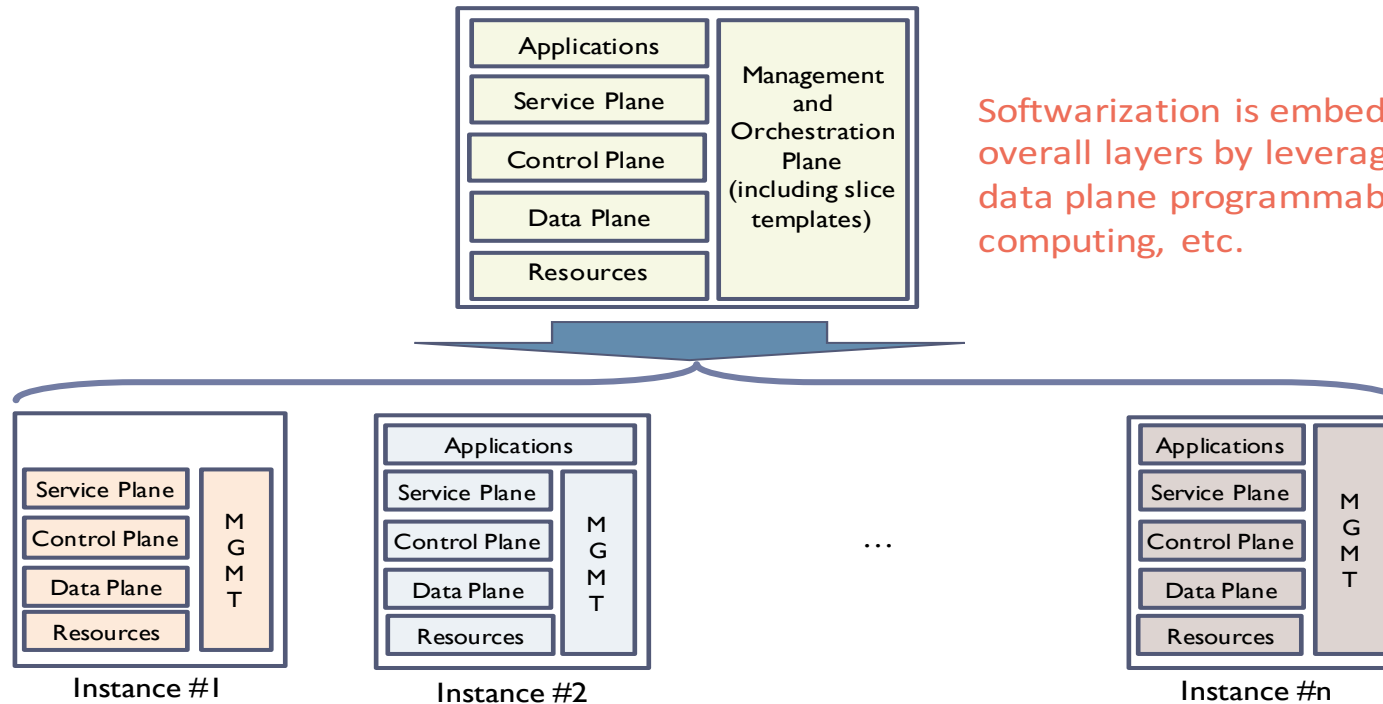

Softwarization is embedded across overall layers by leveraging SDN, NFV, data plane programmability, cloud computing, etc.

Slice instances (eMBB, CritC, etc.)

Conceptual IMT-2020 non-radio network architecture

ITU-T Y.3111 IMT-2020 network management and orchestration framework

ITU-T IMT2020 Slicing Functional Architecture (III)

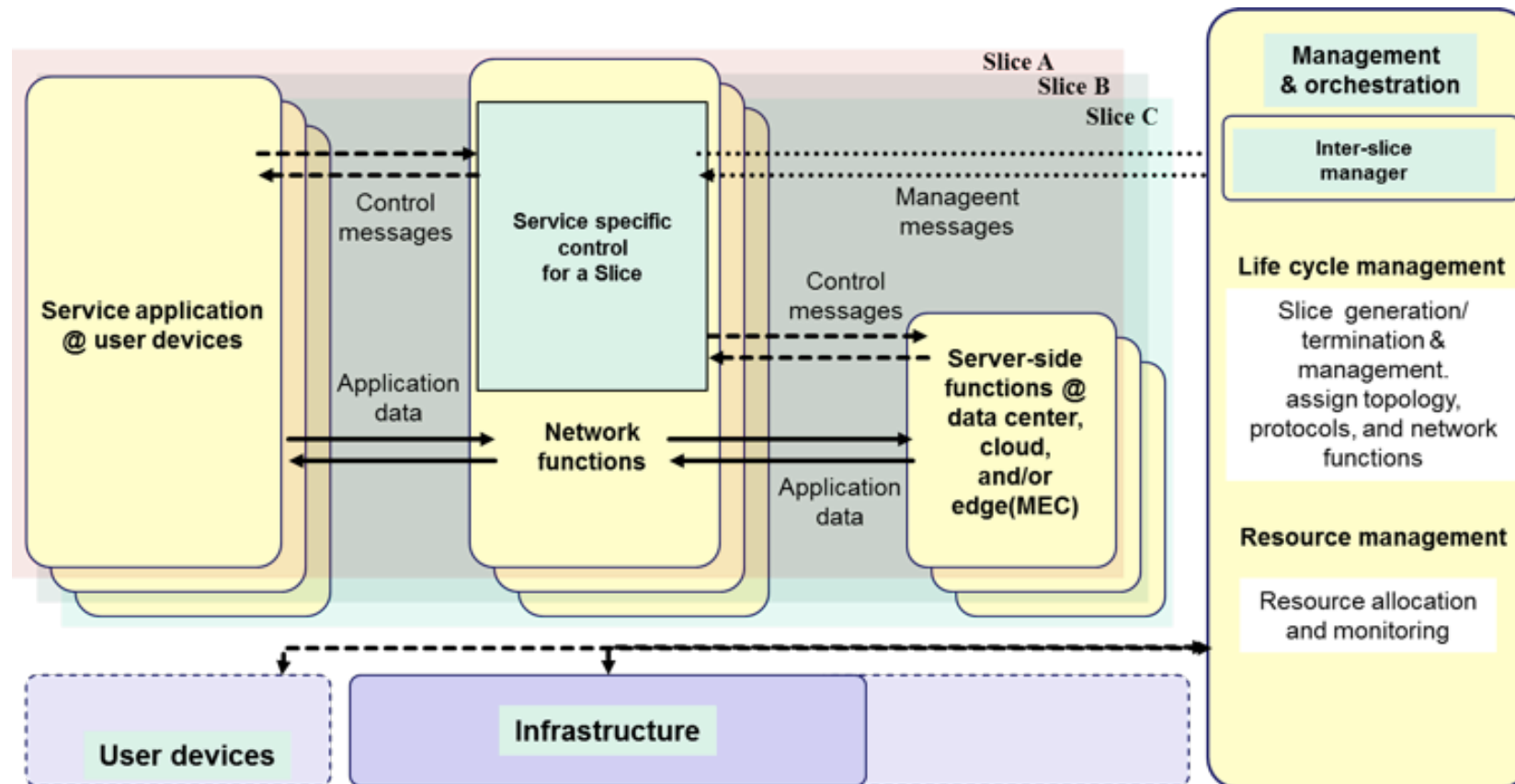

ITU-T IMT2020 Slicing Architecture (IV)

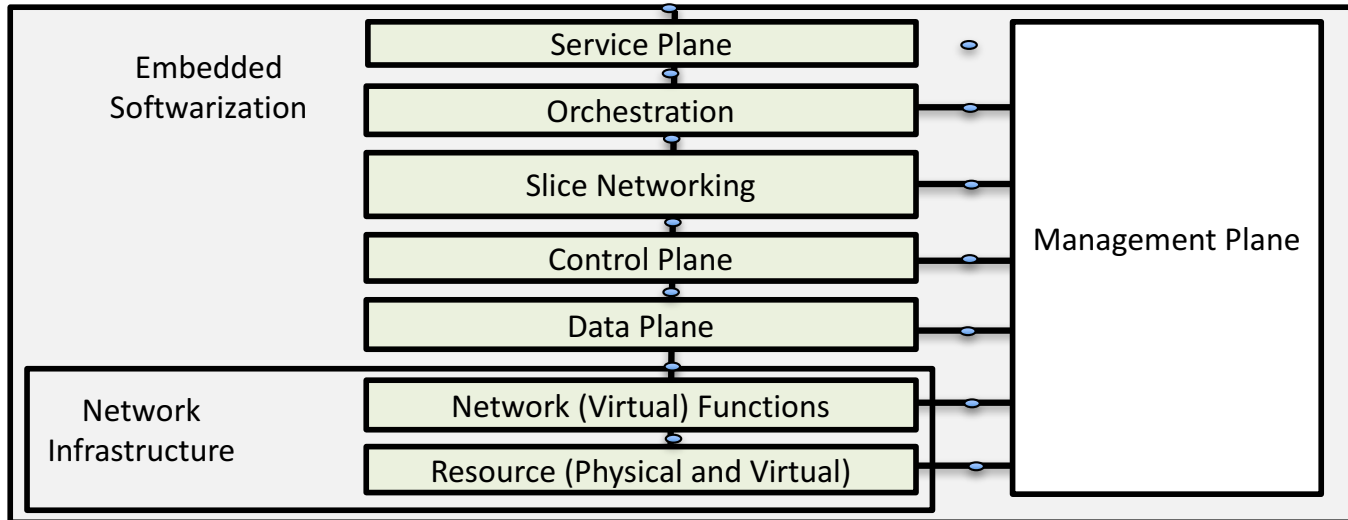

Instantiation

Instances (Service, Management, Control, and Data planes)

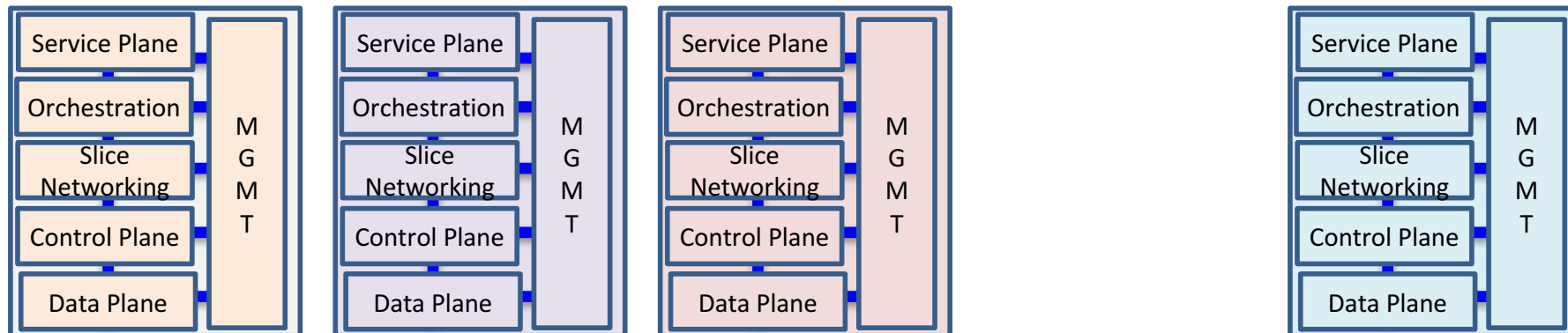

ONF- Open Network Foundation

ONF: <https://www.opennetworking.org>

- ONF TR-521: "SDN Architecture", Issue 1.1, February 2016.
- ONF TR-526: "Applying SDN architecture to 5G slicing", Issue 1, April 2016.
- ONF TR 527: "Functional Requirements for Transport API", June 2016.
- ONF TR-540: "Orchestration: A More Holistic View", January 2017.

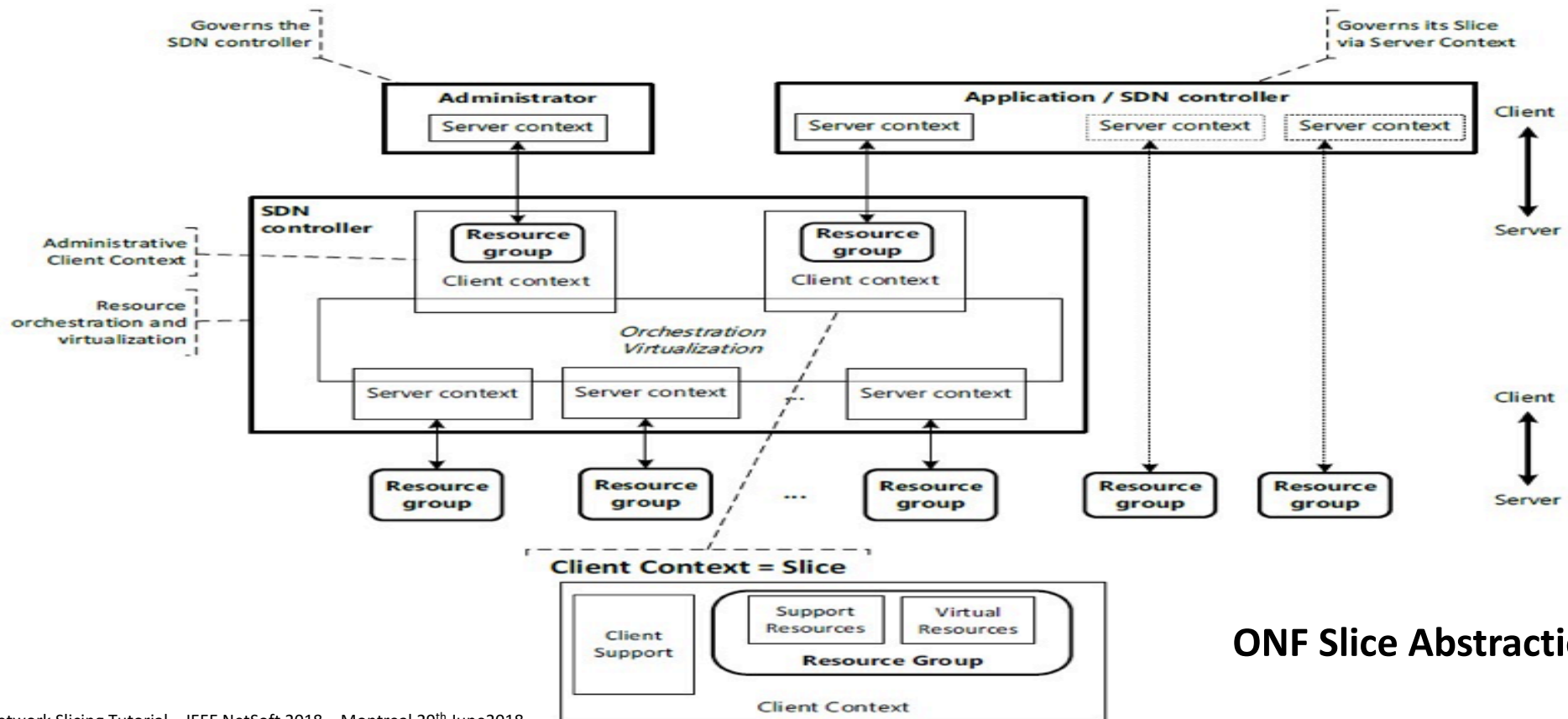

ONF Slice Abstraction

3GPP - 3rd Generation Partnership Project



3GPP: www.3gpp.org/ Published & Work In progress

- 3GPP SA2- Study on Architecture for Next Generation System /Network slice related functionality (3GPP TR 23.799)
- 3GPP SA2- System Architecture for the 5G System /Network slice related functionality (3GPP TS 23.501)
- 3GPP SA2- Procedures for the 5G System: Procedures and flows of the architectural elements/ Network slice related procedures (3GPP TS 23.502)
- 3GPP SA3-Study on the security aspects of the next generation system/ Network slice related security (3GPP TR 33.899)
- 3GPP SA5- Study on management and orchestration of network slicing/ Network slice management (3GPP TR 28.801)
- 3GPP SA5 - Provisioning of network slicing for 5G networks and services: Detailed specification of network slice provisioning/ Network slice management (3GPP TS 28.531)
- 3GPP SA5- Management of network slicing in mobile networks - concepts, use cases and requirements (3GPPTS 28.530)

TS 28.540: Management and orchestration of networks and network slicing; NR and NG-RAN Network Resource Model (NRM); Stage 1.

TS 28.541: Management and orchestration of networks and network slicing; NR and NG-RAN Network Resource Model (NRM); Stage 2 and stage 3.

TS 28.542: Management and orchestration of networks and network slicing; 5G Core Network (5GC) Network Resource Model (NRM); Stage 1.

TS 28.543: Management and orchestration of networks and network slicing; 5G Core Network (5GC) Network Resource Model (NRM); Stage 2 and stage 3.

3GPP network slice stake holders

Communication Service Customer (CSC)

Network Operator (NOP)

Communication Service Provider (CSP),

Network Equipment Provider (NEP),

Virtualization Infrastructure Service Provider (VISP)

Data Centre Service Provider (DCSP),

NFVI (Network Functions Virtualization Infrastructure) Supplier

Hardware Supplier

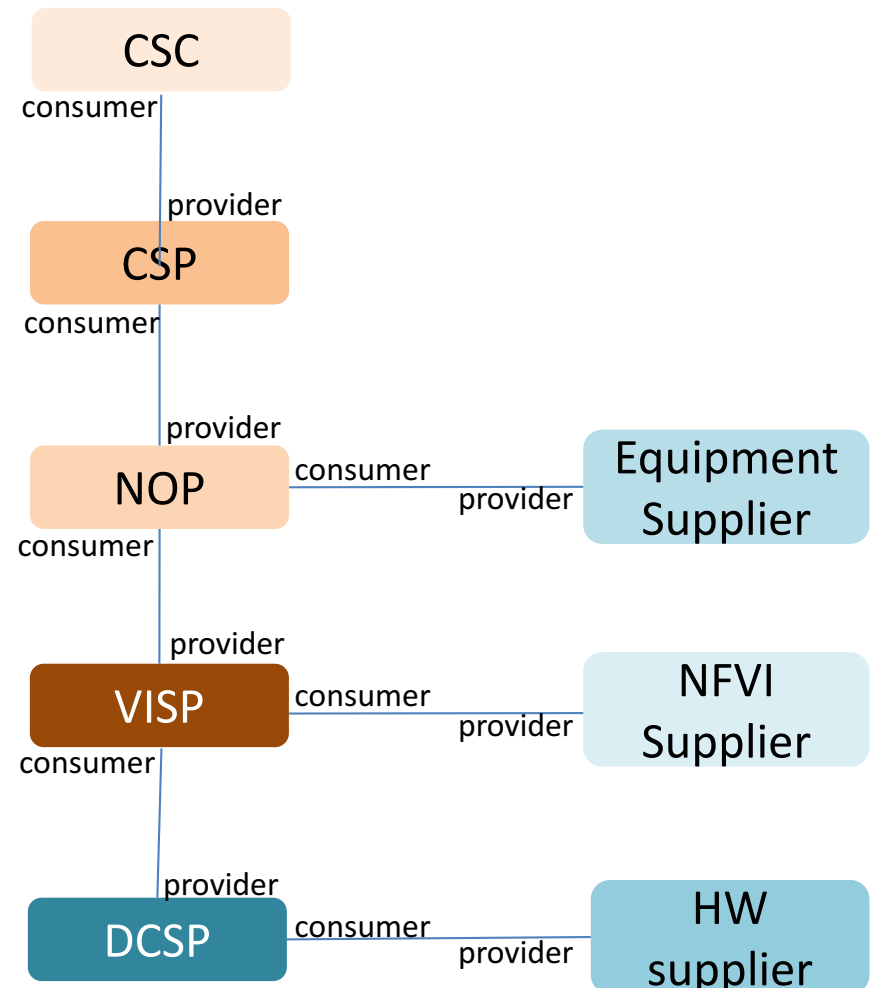

Management Interface and API Centric – Roles are necessary

3GPP – Network Slice Concepts

According to 3GPP TR 28.801 the network slice concept includes the following aspects:

1) Completeness of an NSI: An NSI is complete in the sense that it includes all functionalities and resources necessary to support certain set of communication services thus serving certain business purpose.

2) Components of an NSI: The NSI contains NFs (e.g. belonging to AN and CN). If the NFs are interconnected, the 3GPP management system contains the information relevant to the connections between these NFs such as topology of connections, individual link requirements (e.g. QoS attributes), etc.

For the part of the TN (Transport Network) supporting connectivity between the NFs, the 3GPP management system provides link requirements (e.g. topology, QoS attributes) to the management system that handles the part of the TN supporting connectivity between the NFs.

3) Resources used by the NSI: The NSI is realized via the required physical and logical resources.

4) Network Slice Template: The network slice is described by a Network Slice Template (NST). The NSI is created using the NST and instance-specific information.

5) NSI policies and configurations:

Instance-specific policies and configurations are required when creating an NSI.

Network characteristics examples are ultra-low-latency, ultra-reliability, etc.

NSI contains a Core Network part and an Access Network part.

6) Isolation of NSIs: A NSI may be fully or partly, logically and/or physically, isolated from another NSI

3GPP Network Slicing intricacies

- Based on Service oriented architecture
- It sees subnet as group of network functions.
- Network Slice subnet instance (NSSI) can be shared or non-shared across different slices (due to 3GPP, functions).
- 2 ways to manage slices: (1) build a service, do not expose slice, (2) offer slice as a service (NSaaS).
- Communication with Non-3GPP (TN and DCSN)

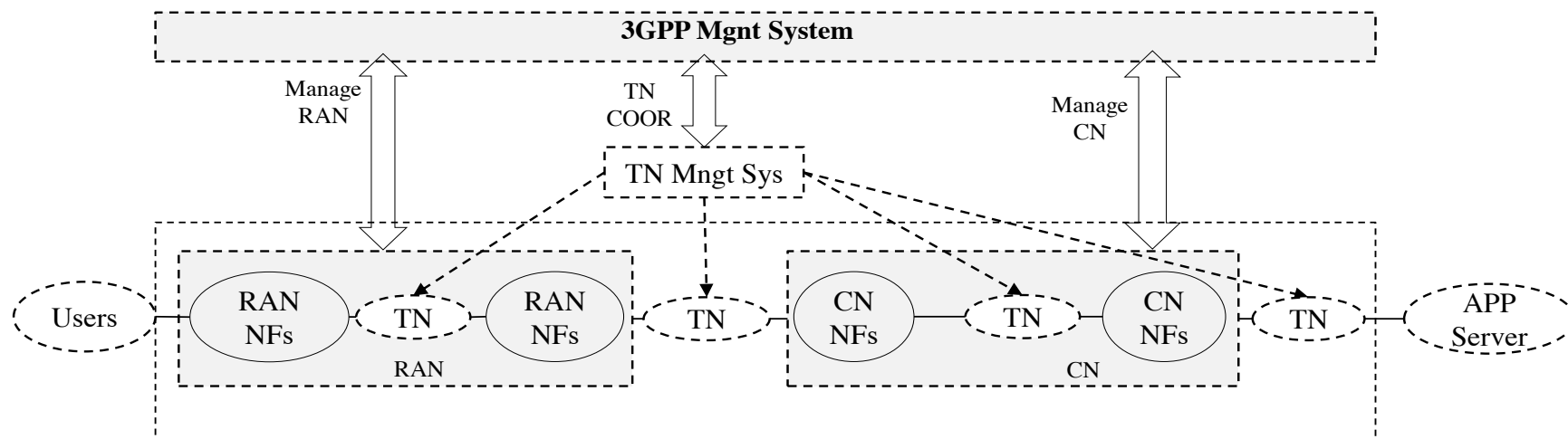

3GPP Scope (Information Modeling)

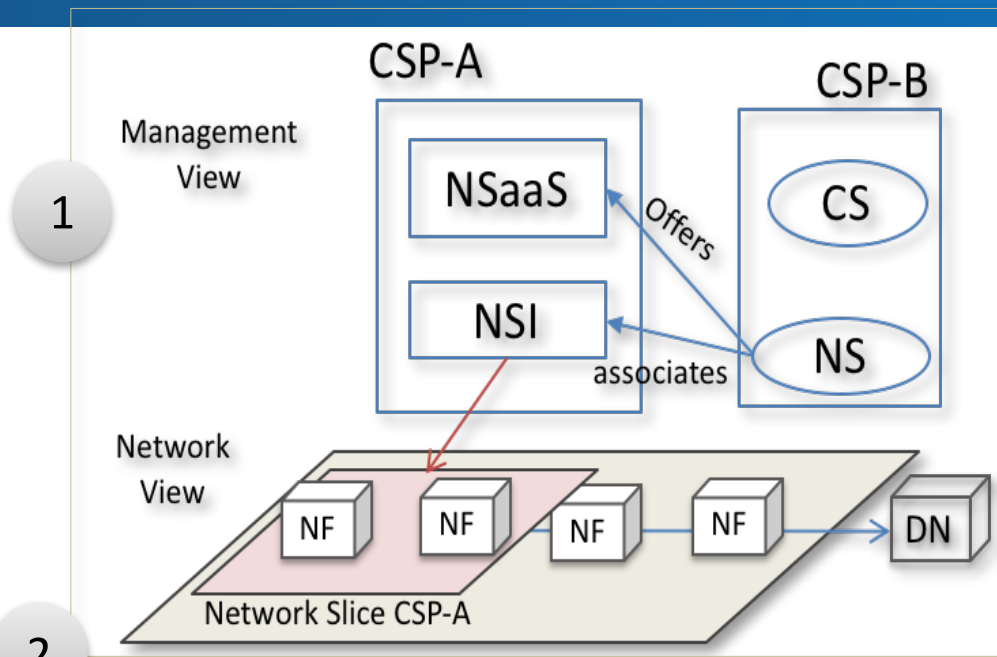

- 2**
- Capability Model** *traffic, subscriber density, QoS, mobility..*
 - Resource Model** *components of network slice subnet, (1) NSST ID, (2) type, (3) system feature (e.g. multicast, Edge Computing), priority, QoS attributes*
 - Mgmt Model** *lifecycle management: configuration profile.*

Type: eMBB, MIoT, URLLC
 Industry: V2X, smart grid, Remote Healthcare

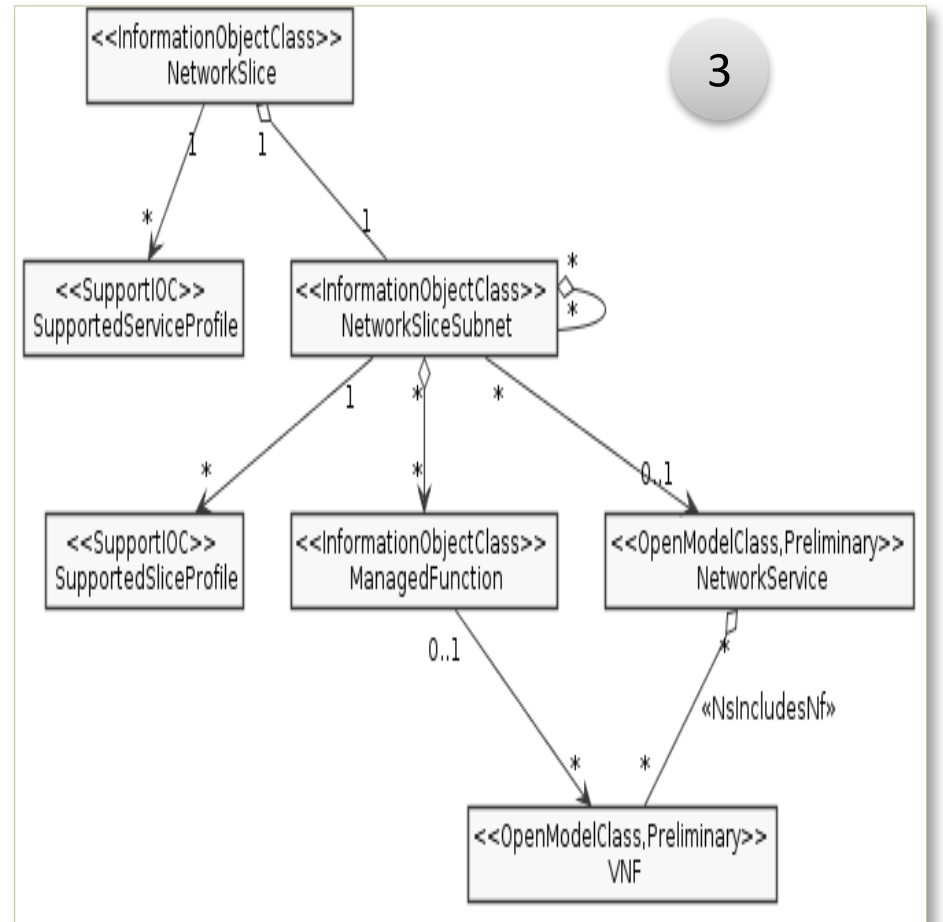

3GPP Network slice management in an NFV framework

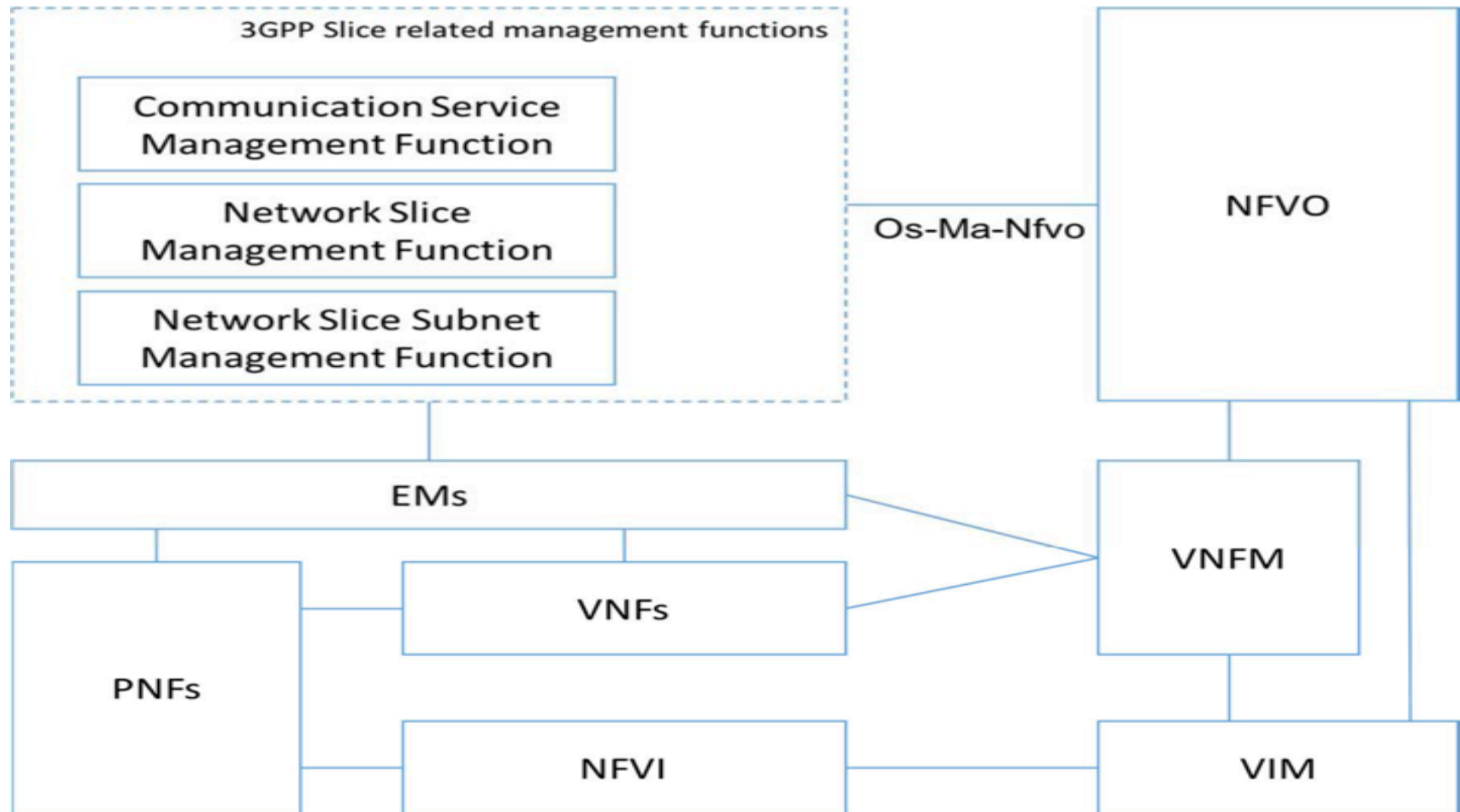

3GPP Network Slice Information model



According to 3GPP TR 28.801 a network slice subnet instance (NSSI) can be shared by multiple NSIs. The virtualised resources for the slice subnet and their connectivity to physical resources can be represented by the nested NS concept defined in ETSI or one or more VNFs directly attached to the NS used by the network slice.

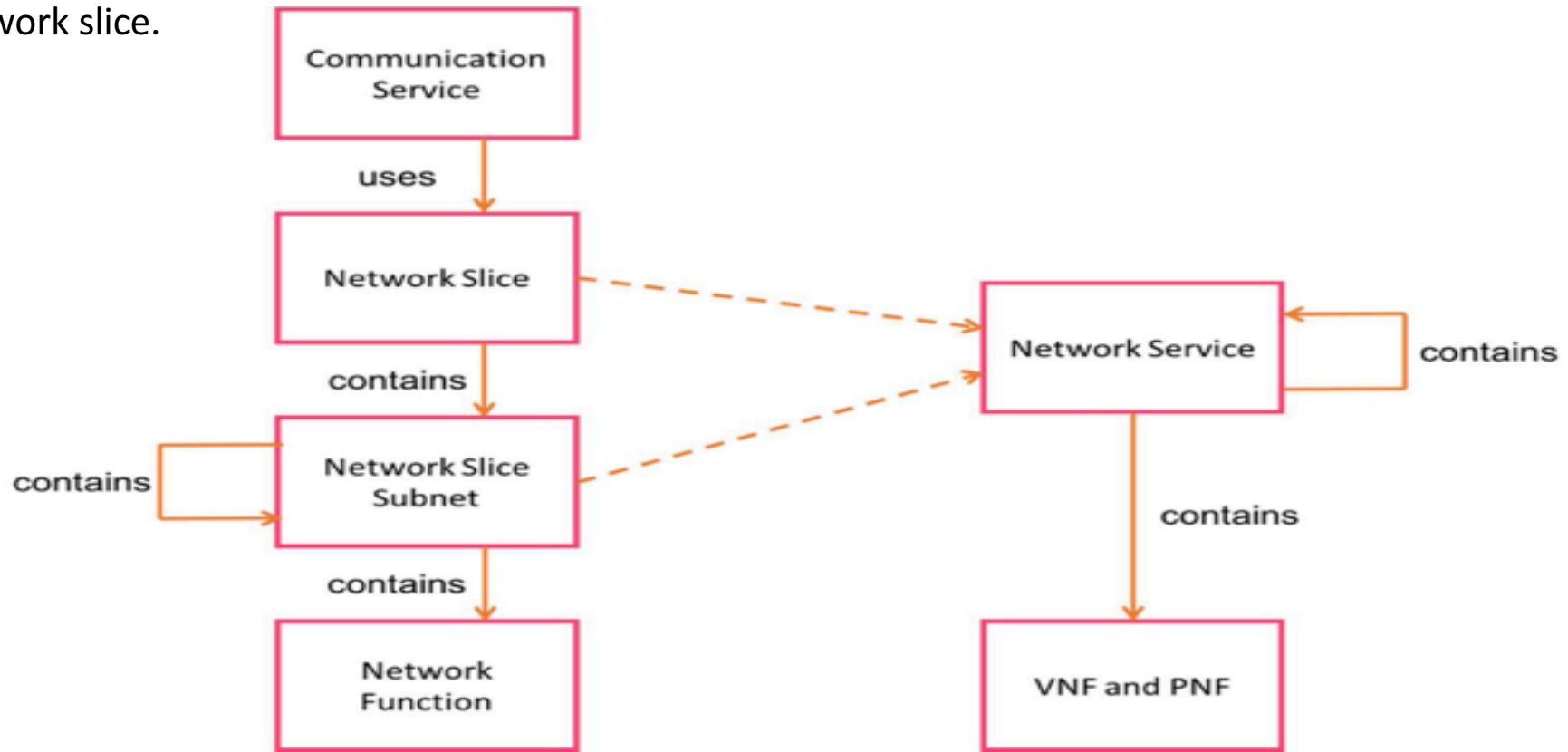

3GPP-ETSI: Relating the information models

- Network Operator Perspectives on NFV priorities for 5G-
https://portal.etsi.org/NFV/NFV_White_Paper_5G.pdf
- Report on Net Slicing Support with ETSI NFV Architecture Framework http://www.etsi.org/deliver/etsi_gr/NFV-EVE/001_099/012/03.01.01_60/gr_NFV-EVE012v030101p.pdf
- E2E Network Slicing Framework
[https://docbox.etsi.org/ISG/NGP/05-CONTRIBUTIONS/2018//NGP\(18\)000061](https://docbox.etsi.org/ISG/NGP/05-CONTRIBUTIONS/2018//NGP(18)000061)
 - It fills the gap of holistic architecture, independent of any technology or specific framework
- ETSI GS NGP 001: "Next Generation Protocol (NGP); Scenario Definitions". <http://www.etsi.org/technologies-clusters/technologies/next-generation-protocols>

ETSI – NFV ISG

- Network Operator Perspectives on NFV priorities for 5G-
https://portal.etsi.org/NFV/NFV_White_Paper_5G.pdf
- Report on Net Slicing Support with ETSI NFV Architecture Framework
http://www.etsi.org/deliver/etsi_gr/NFV-EVE/001_099/012/03.01.01_60/gr_NFV-EVE012v030101p.pdf
- ETSI GS NGP 001: "Next Generation Protocol (NGP); Scenario Definitions".
<http://www.etsi.org/technologies-clusters/technologies/next-generation-protocols>

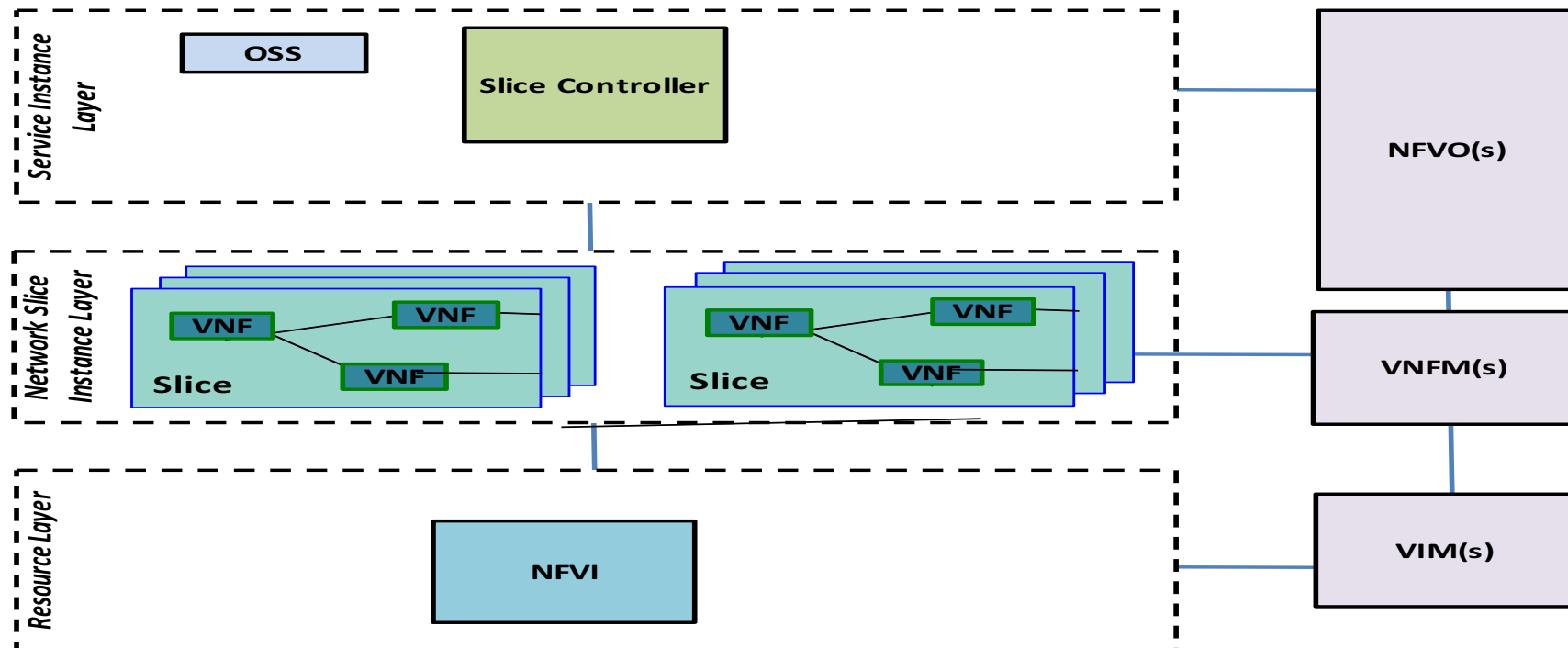

Opportunity to integrate Network Slice across almost all the layers in NFV architecture

Revisited ETSI NFV Framework

Opportunity to integrate Network Slice across almost all the layers in NFV architecture

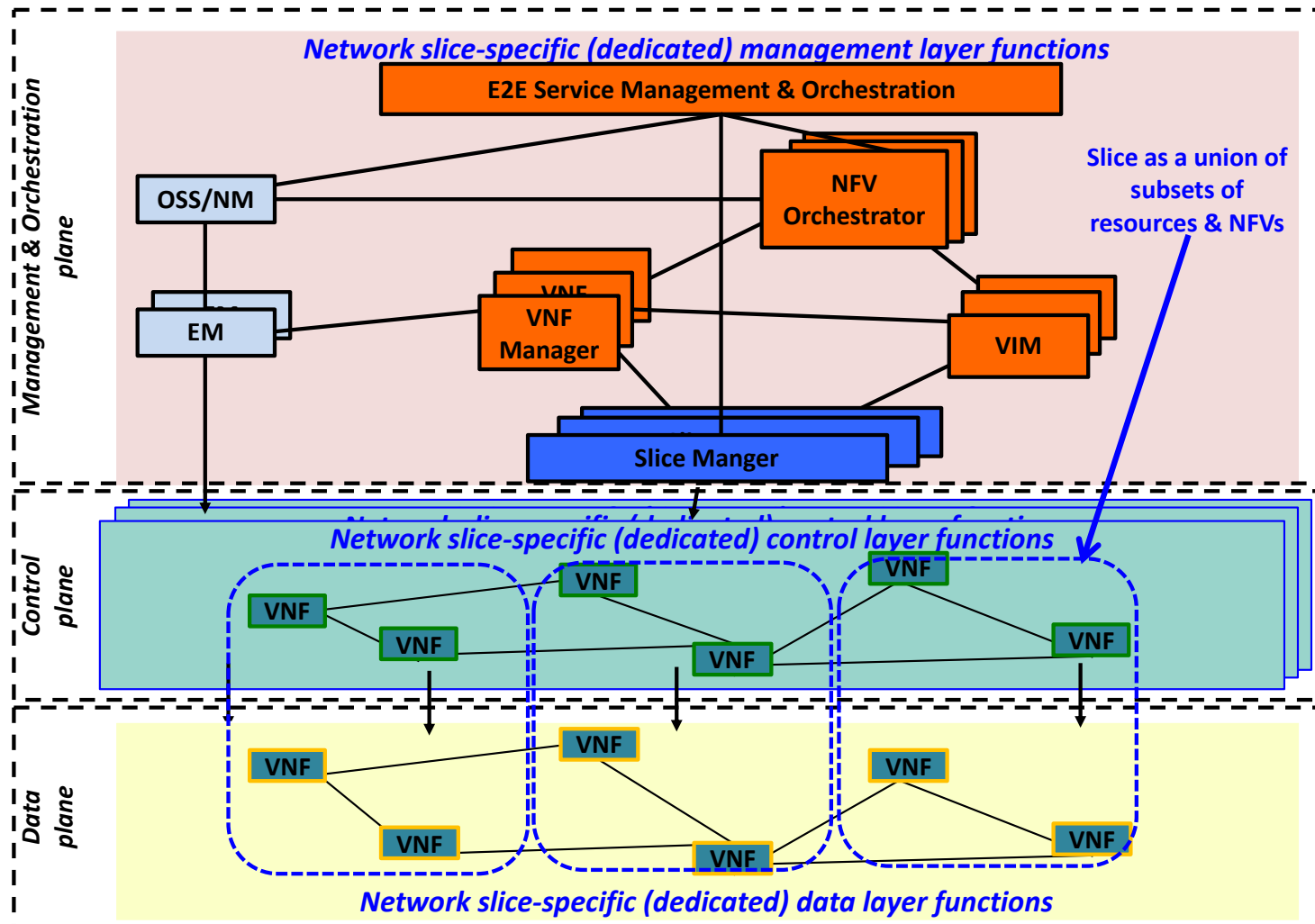

ETSI NFV

Control Plane / User Plane Separation BNG

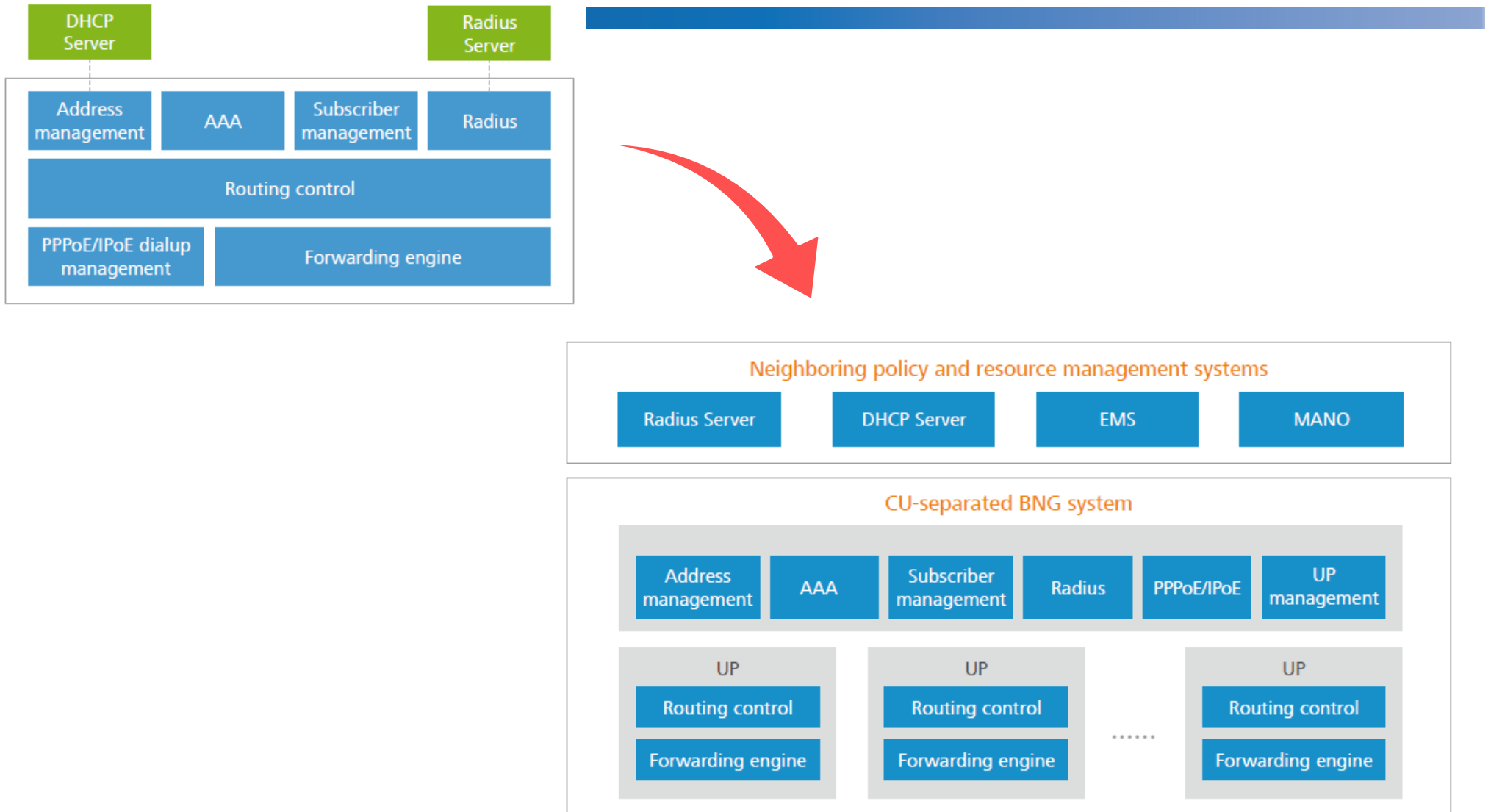

Control Plane / User Plane Separation - BNG

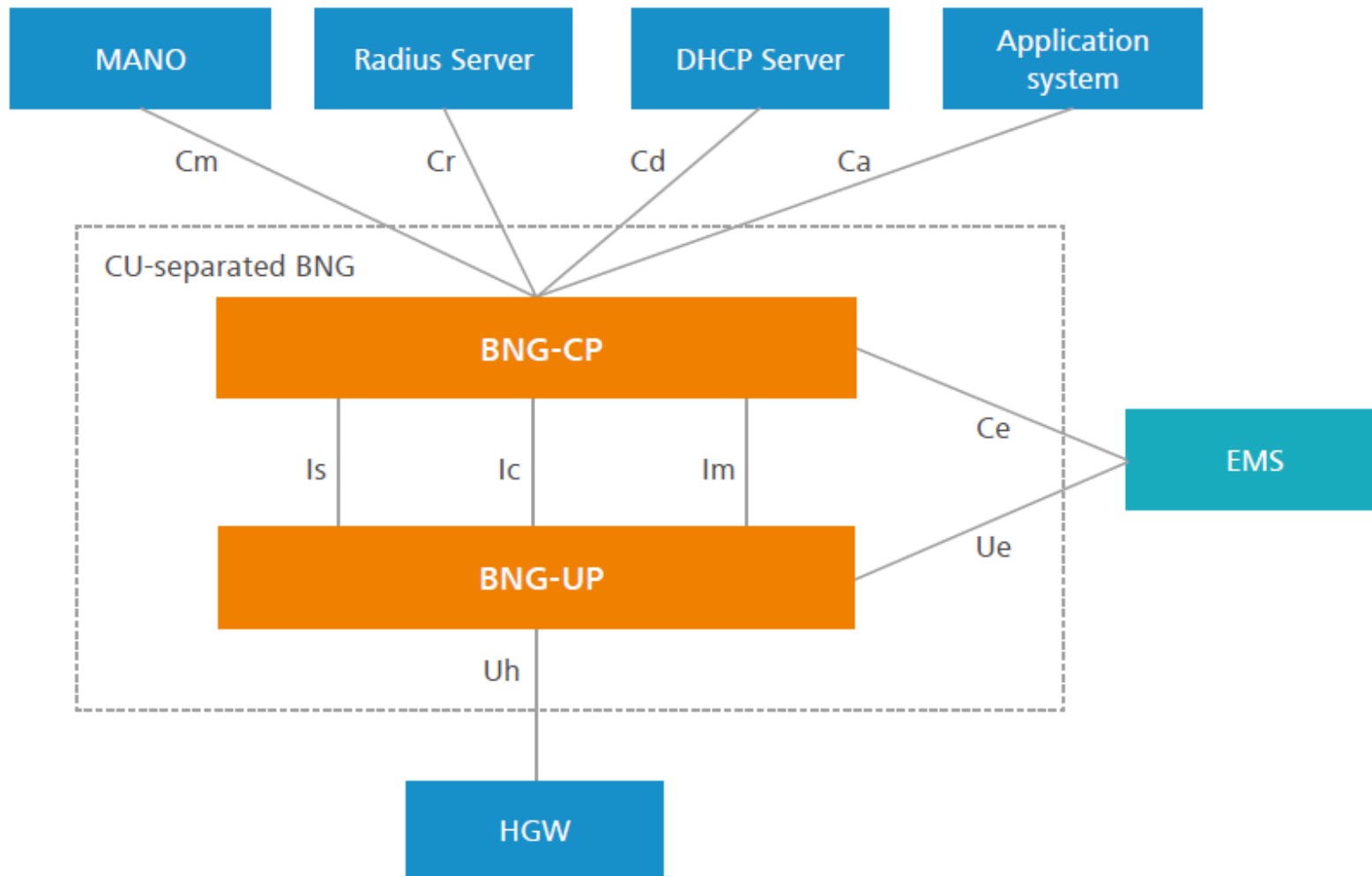

Control Plane / User Plane Separation – Packet Core

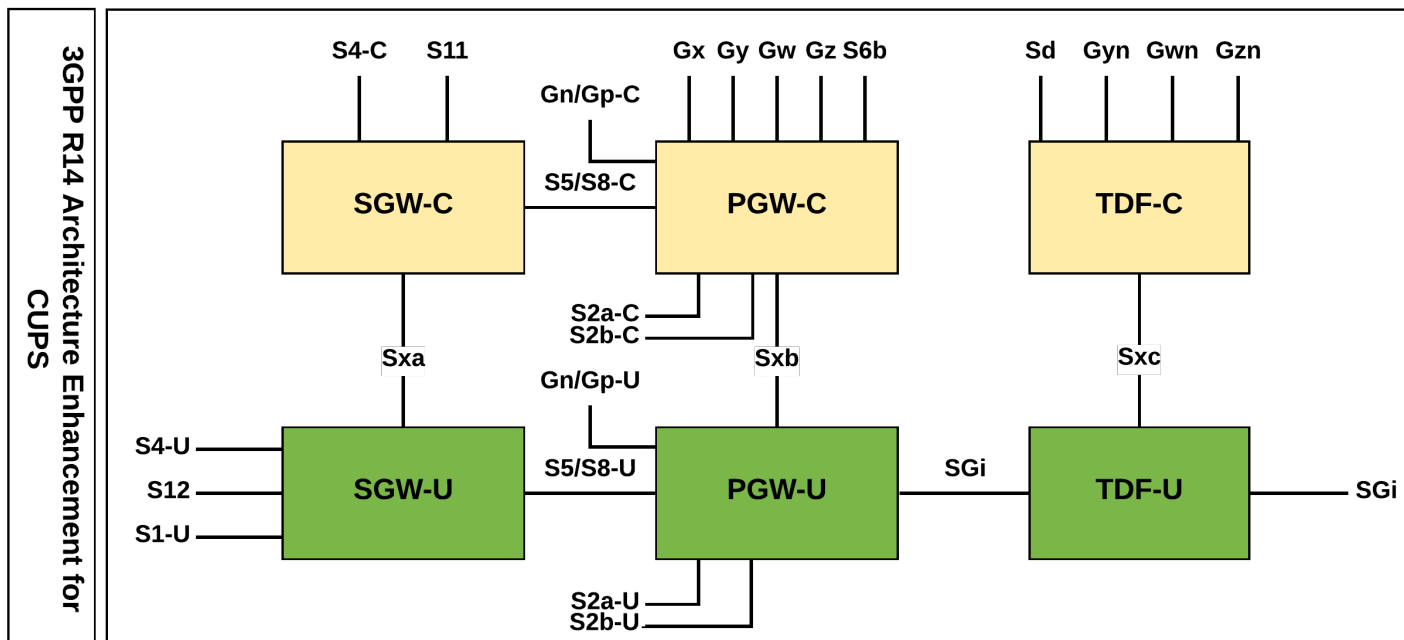
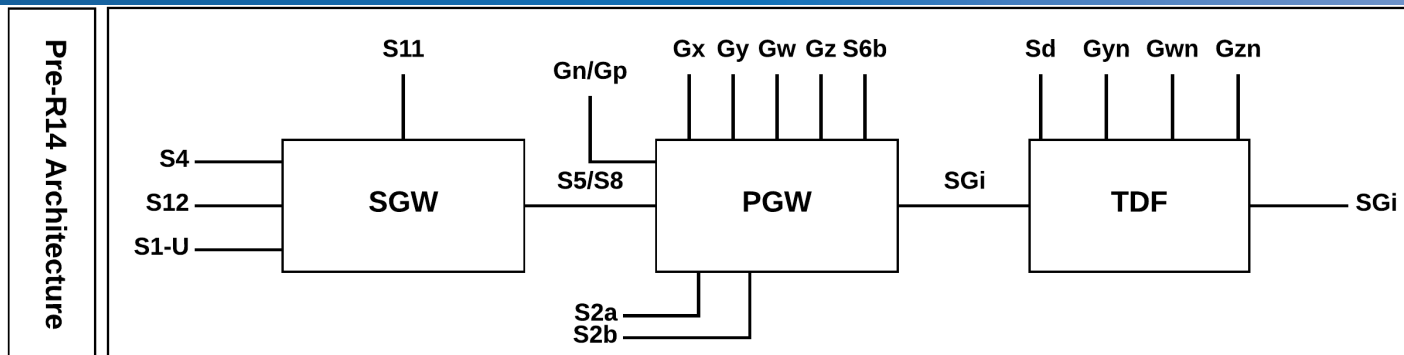

Control Plane / User Plane Separation – Packet Core

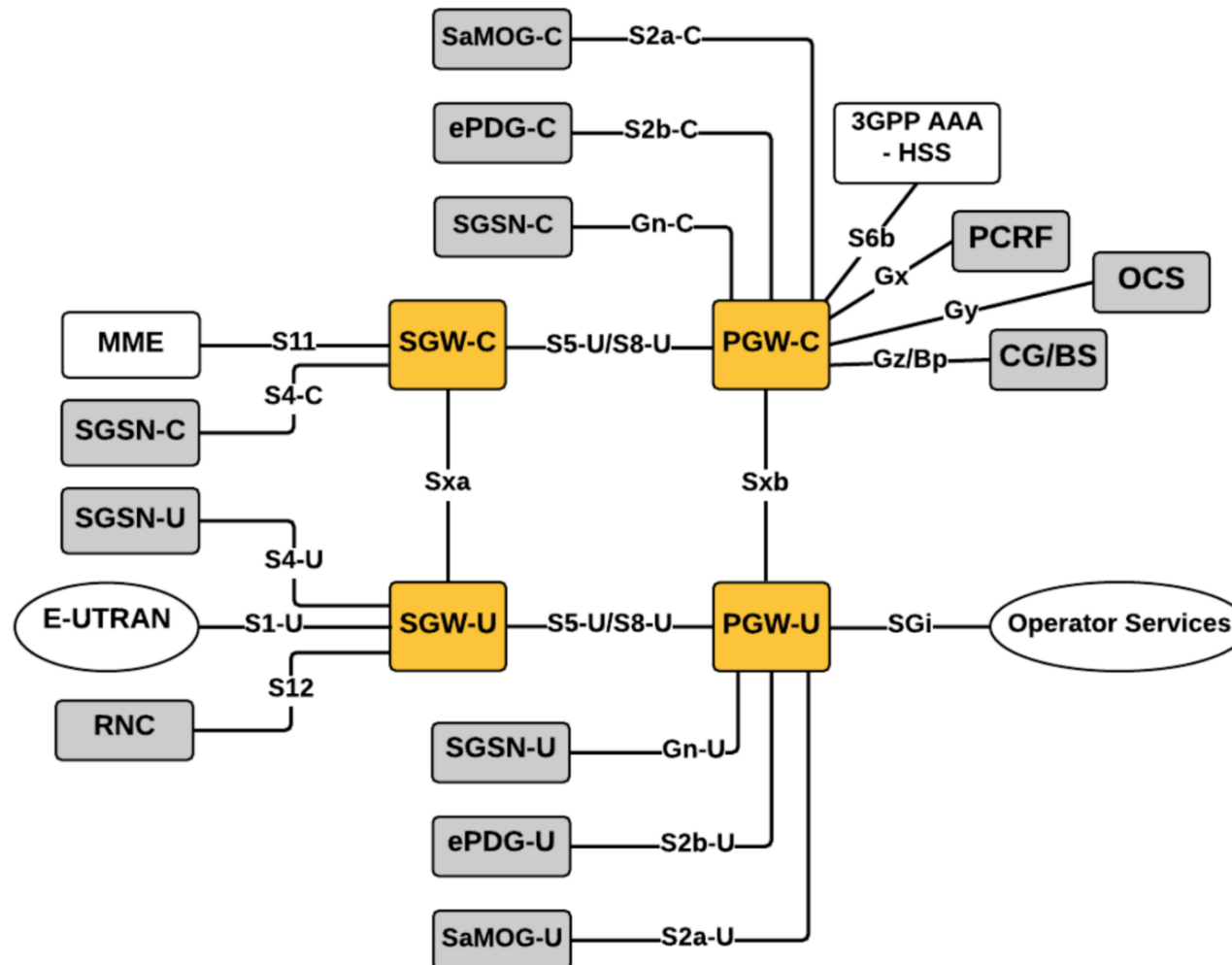

A network slice is a graph of network functions (VNF, PNF) connected together to build an end-to-end network service with specific requirements and capabilities. Several network functions may be common to different slices.

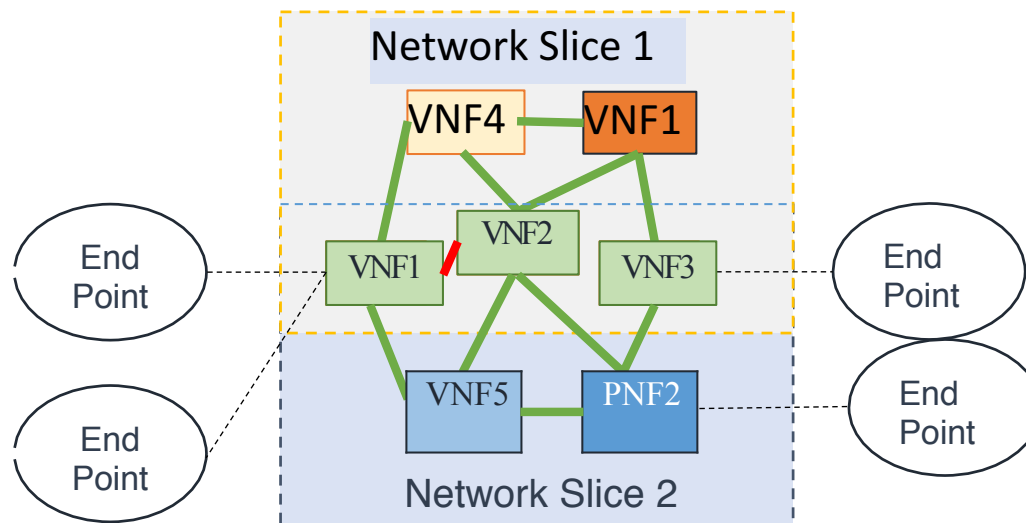

Network slices with common VNFs

ETSI Network slicing deployment applying NFV concepts to achieve isolation

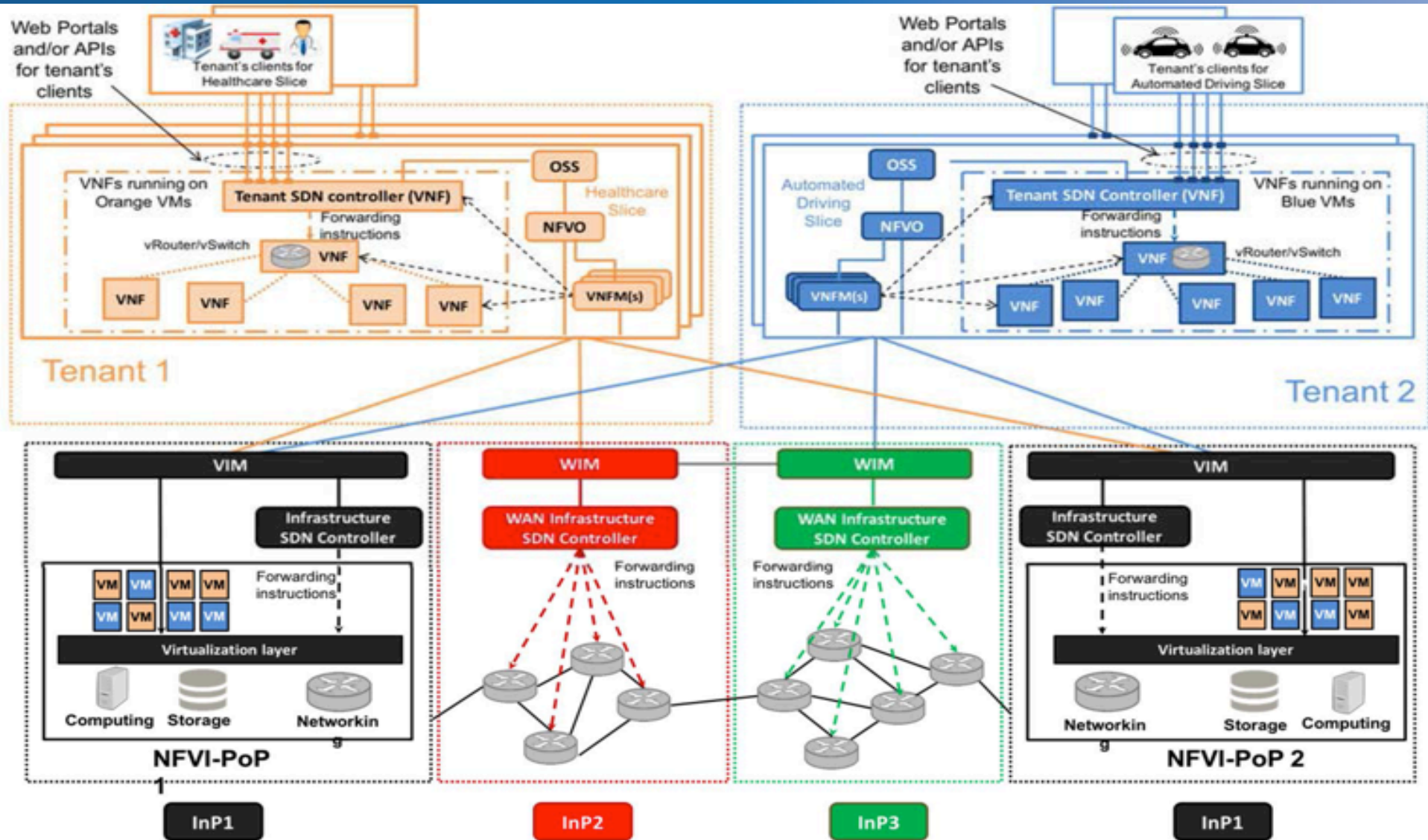

ETSI NGP: Network Slice reference framework

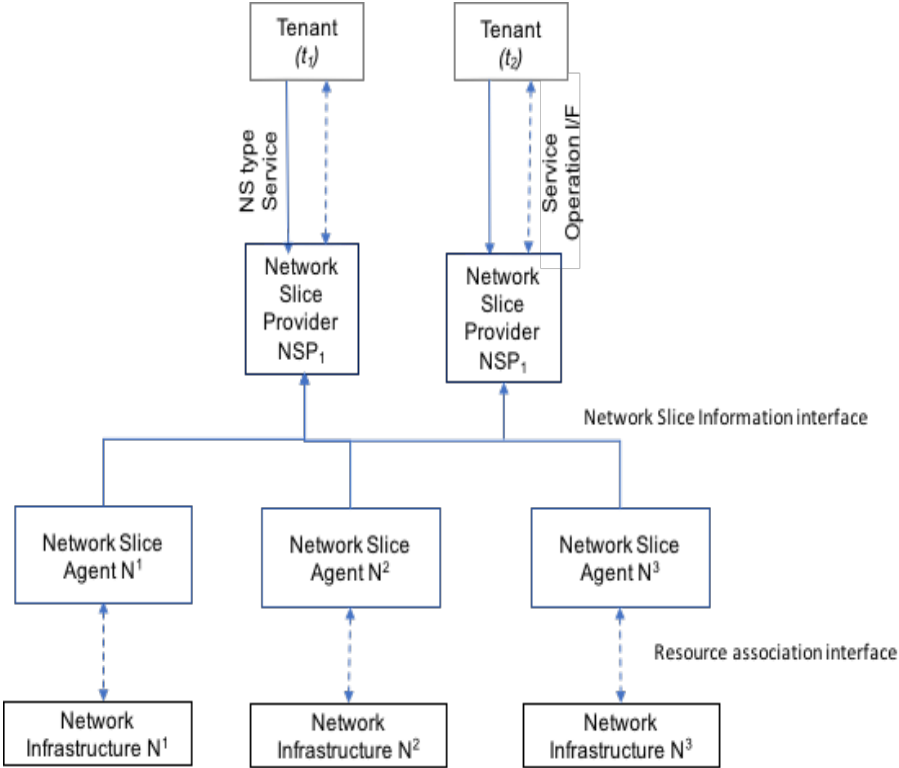

HL Interface Model

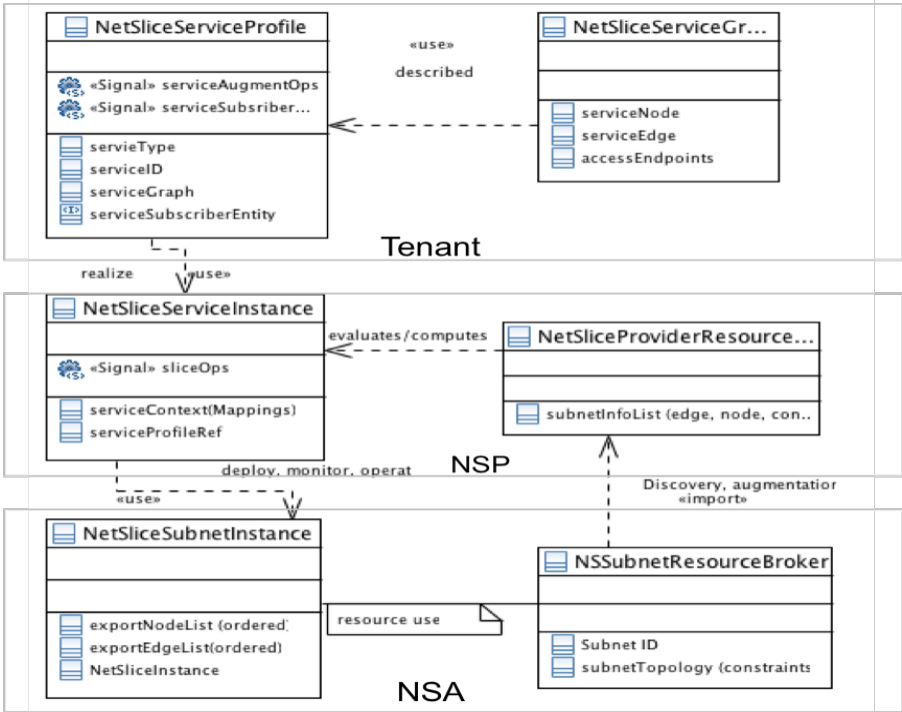

HL Data Object Model

Information Model: (a) Reference interfaces in Framework (b) describes the primary data objects, and (c) different functions required to manage end-to-end slices

NGP provides a completely independent of any existing technology existing architecture. It can be used as a guidance, identify your own functional components and/or communications.

ETSI NGP: Flow of Information and function responsibility



1. **NSA_DISCF**: NS subnet discovery
Coordination, export of resources by network infrastructure
2. **NSP_RCF**: Resource computation function
Local decision to find tenant service graph
3. **NSP_MAPF**: Network slice mapping function
service graph to discovered resource maps
4. **NSP_DELGNF**: Delegation function
allocate and resource reservation in infrastructure
5. **NSA_AUGF**: NS subnet augment function
negotiations on resource changes at macro level
6. **NSA_REPF**: Reporting Function
Determine network resource state and health for accounting
7. **NSA_SVCF**: Service assurance function
Allows tenant to perform and query service assurance
8. **NSA_TENOPSF**: Tenant Ops function: Create, query modify, delete etc..

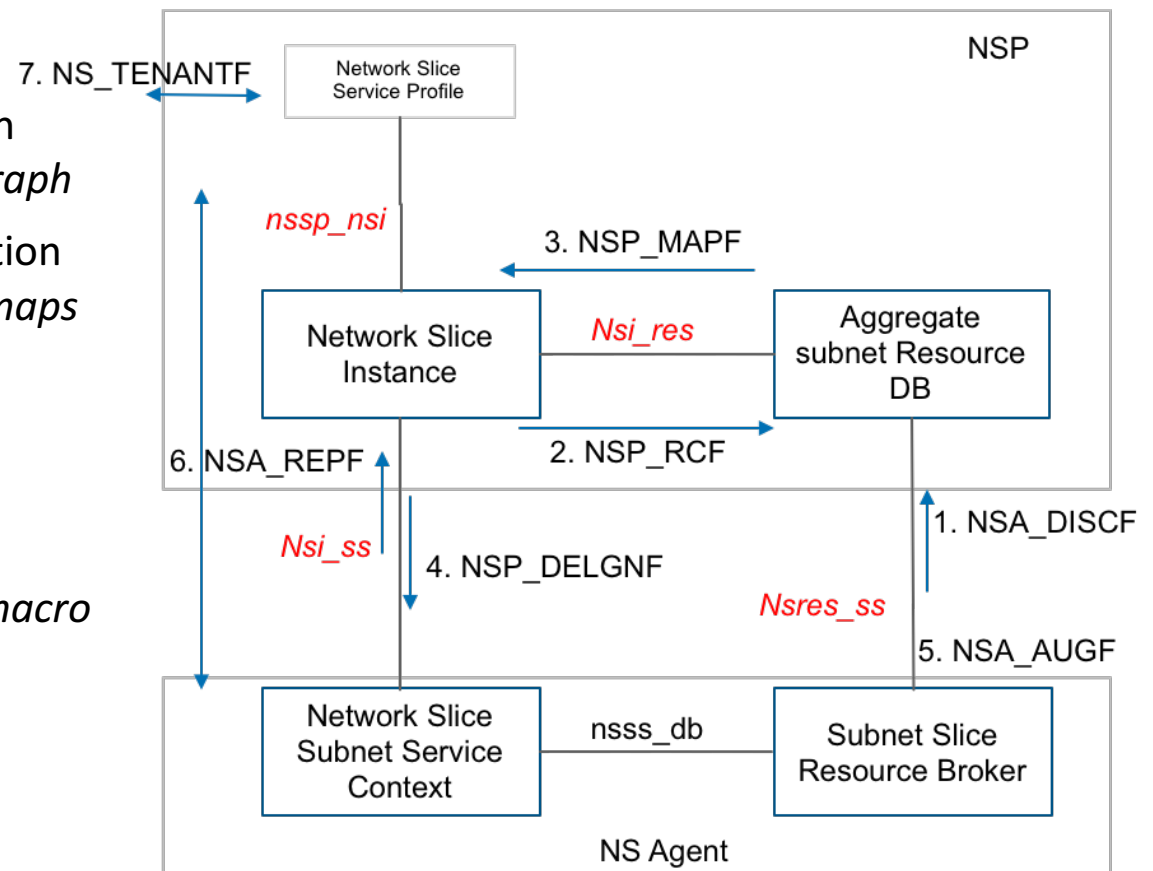

BBF – Broadband Forum

BBF - <https://www.broadband-forum.org/5g>

- Fixed Access Network Sharing (FANS)
- Requirements / architecture of transport network slicing SD-406: End-to-End Network Slicing

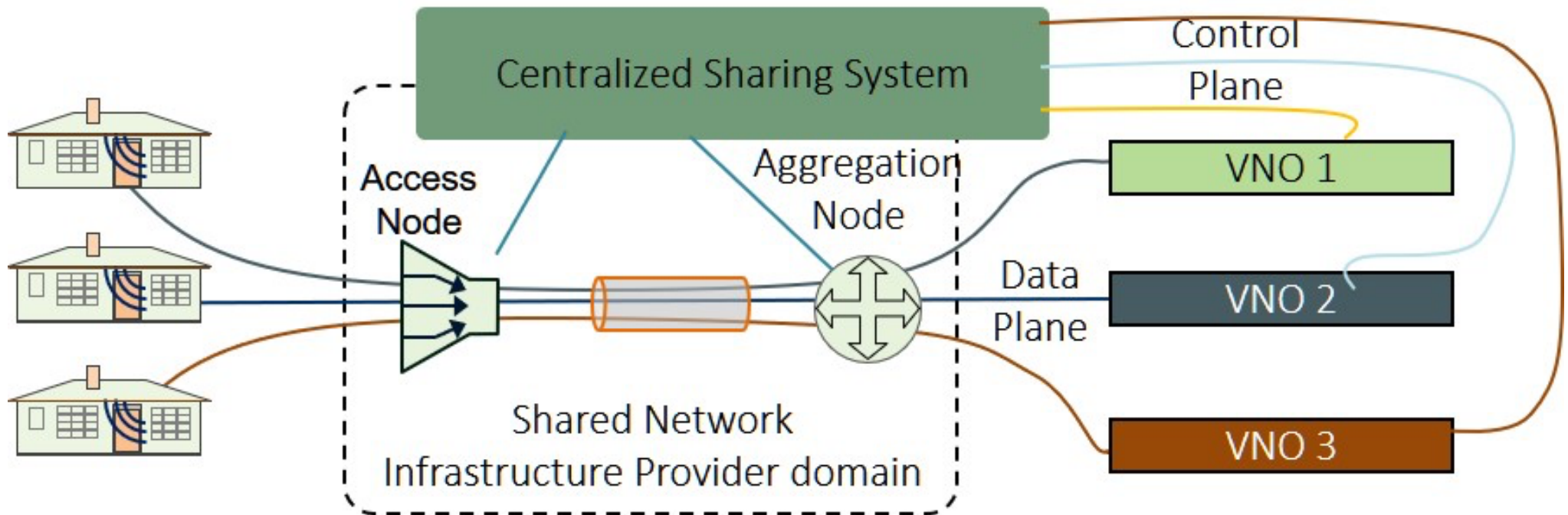

Network Sharing sowing Network Slices in different colors

IETF- Internet Engineering Task Force



IETF - <https://www.ietf.org>

- Network Slicing - Revised Problem Statement [draft-galis-netslices-revised-problem-statement-03](#)
- NetSlices Architecture [draft-geng-netslices-architecture-02](#)
- NetSlices Management Architecture [draft-geng-coms-architecture-01](#)
- NetSlices Use Cases [draft-netslices-usecases-01](#)
- NetSlices Management Use cases [draft-qiang-coms-use-cases-00](#)
- NetSlices Information Model [draft-qiang-coms-netslicing-information-model-02](#)
- Autonomic NetSlicing [draft-galis-anima-autonomic-slice-networking-04](#)
- NetSlices Interconnections <https://tools.ietf.org/html/draft-defoy-coms-subnet-interconnection-03>
- NetSlicing Gateway Function <https://tools.ietf.org/html/draft-homma-coms-slice-gateway-01>
- Framework for Abstraction and Control of Traffic Engineered Networks (ACTN) <https://tools.ietf.org/html/draft-ietf-teas-actn-framework-14>

IETF - Network Slicing Reference Architecture



- Network Slice Provider (NSP) & Network Slice Tenant (NST)
 - Communicate with NS M&O system via northbound interface
- Network slice management & orchestration
 - Lifecycle mngt to coordinate E2E and Domain Orchestration
 - Template/NS repository to assist life cycle mngt.
 - Resource Registrar to manage exposed network infrastructure capabilities
 - NS Manager to oversee individual slice (capability exposure to NST)
- Network infrastructure owner
 - Control plane for slice instantiation and adjustment
 - Data plane for guaranteed performance and isolation

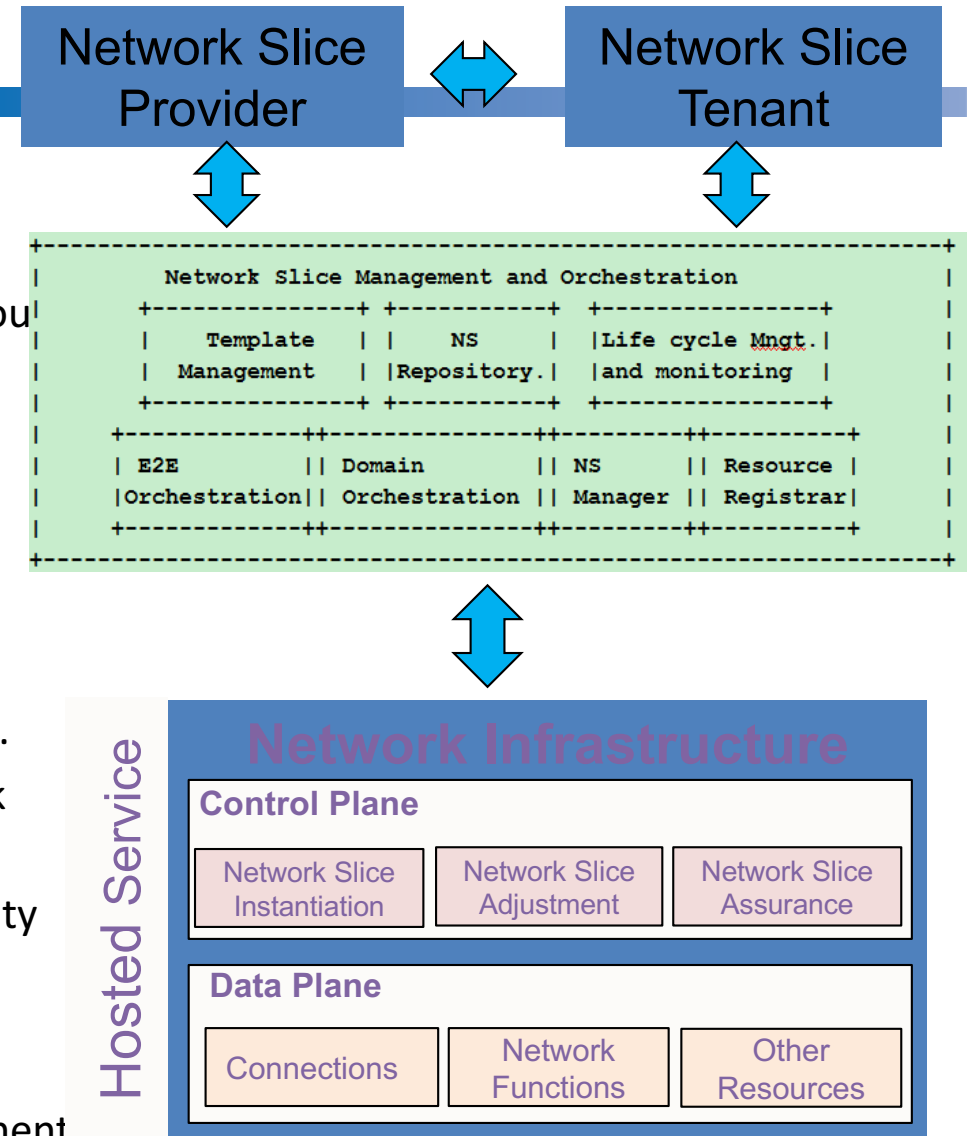

IETF Management Viewpoint

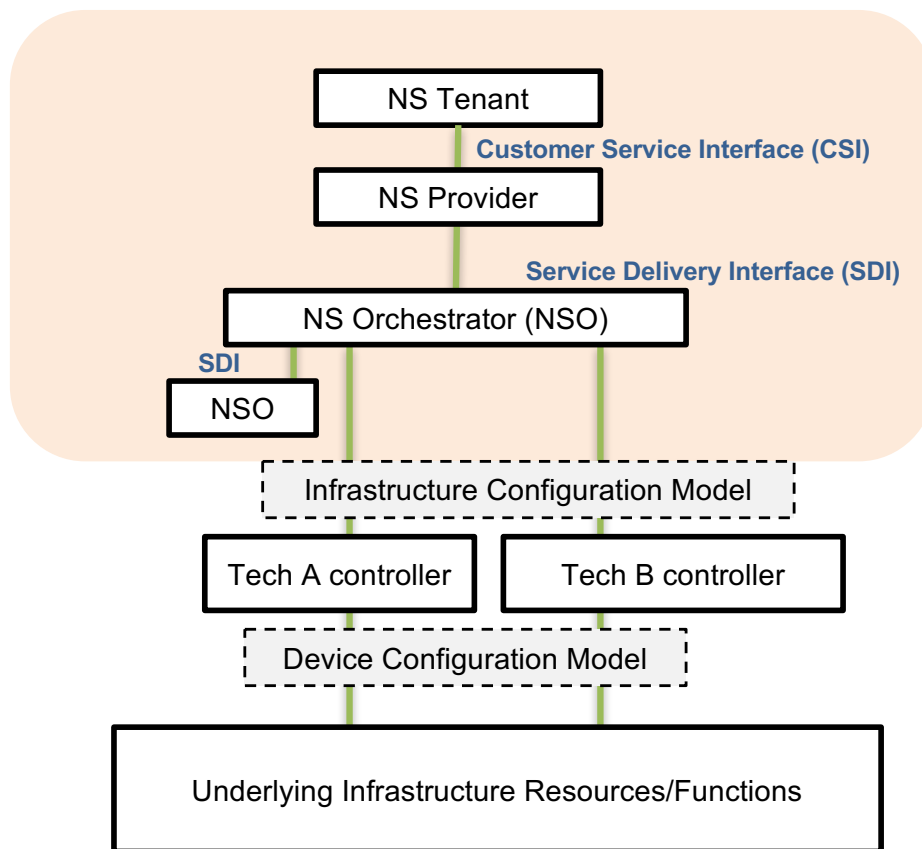

- Customer Service Interface (CSI)
- Service Delivery Interface (SDI)

Each may consist of several data models. Corresponding operation model and guidelines are also in scope

- Information model
- Other operation enablement (interconnection, gateway etc..)

CSI & SDI specification

Suggestions:

CSI – Customer Service Interface

- Service deployment request
- Network slice tenant in a “NSaaS” environment
- Negotiation cycles with NS provider
- Network slice, subnets and related service functions parameters
- Interface ID, configuration and monitoring

SDI – Service Delivery Interface

- Triggers slice design and instantiation
- Service on-boarding using orchestration logics
- Slice instantiation /update / subnet
- Based upon relevant data model; Interface ID, configuration and monitoring

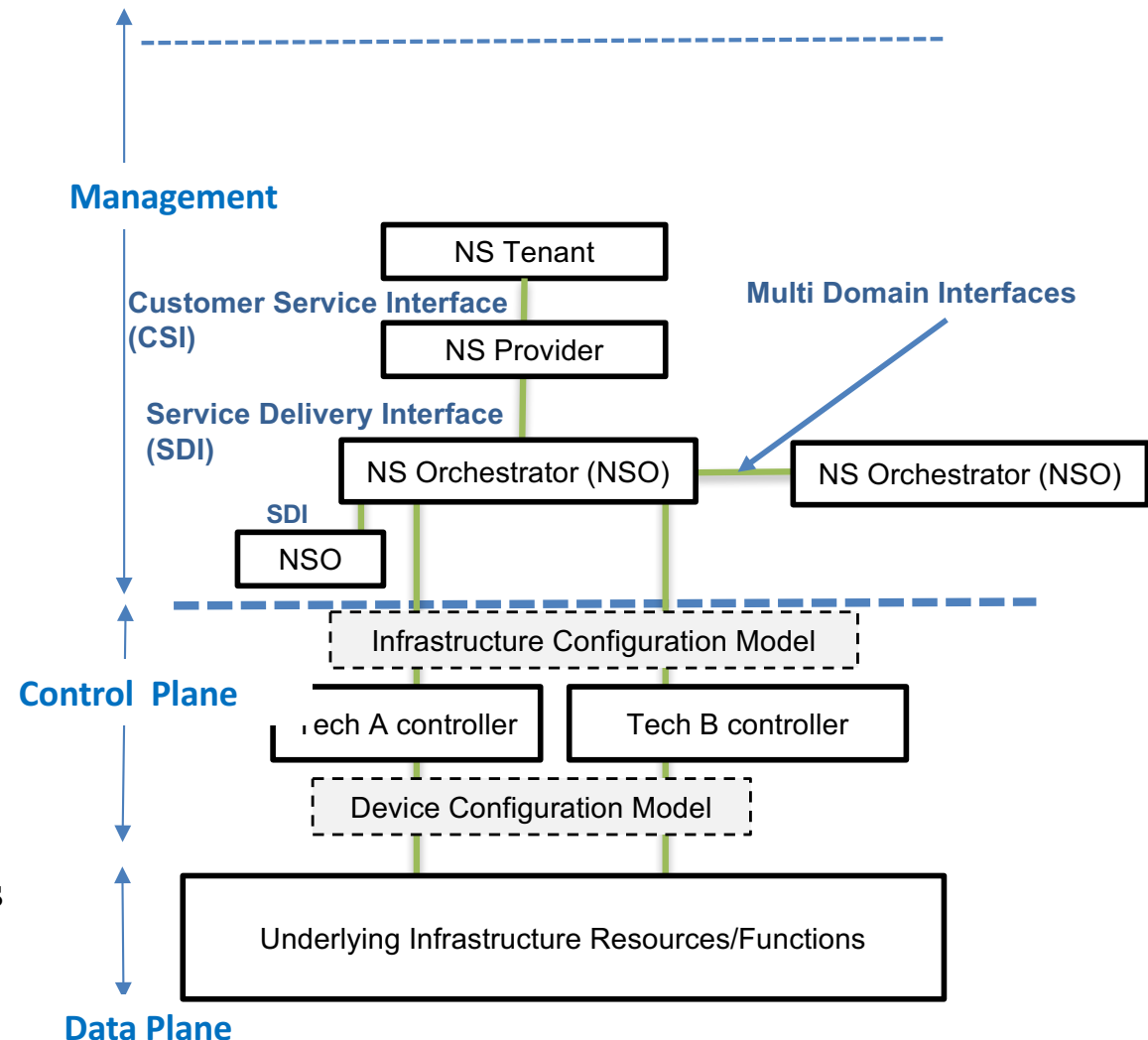

Summary Of SDO efforts

- **3GPP** – Valuable platform for slicing (NG-R and 5GC)
- **NGMN** – Described slicing concept for 5G with IMT2020
- **ITU-T** Slices work in IMT-2020, SG13 and SG15 – covering management & transport aspects; alignment with 5G.
- **ONF, BBF, ETSI-NFV** – for SDN and NFV capabilities for slices
- **ETSI-NGP** – Technology independent holistic approach to slicing
- **IETF** – focused on fixed network and management. Slices are expected to use existing mature data plane technologies.

Contents List

1. Key Slicing concepts and history
2. Slicing Key Characteristics & Usage scenarios & Value Chain
3. Multi-Domain Network Function Virtualisation
4. Review of Research projects and results in network and cloud slicing
5. Open Source Orchestrators
6. Standard Organization activities: NGMN, ITU-T, ONF, 3GPP, ETSI, BBF, IETF
7. Industrial perspective on Network Slicing
8. Review of industry Use Cases
9. Network Slicing Challenges
10. Concluding remarks of Network Slicing
11. Acknowledgements & References

Industry Stakeholders

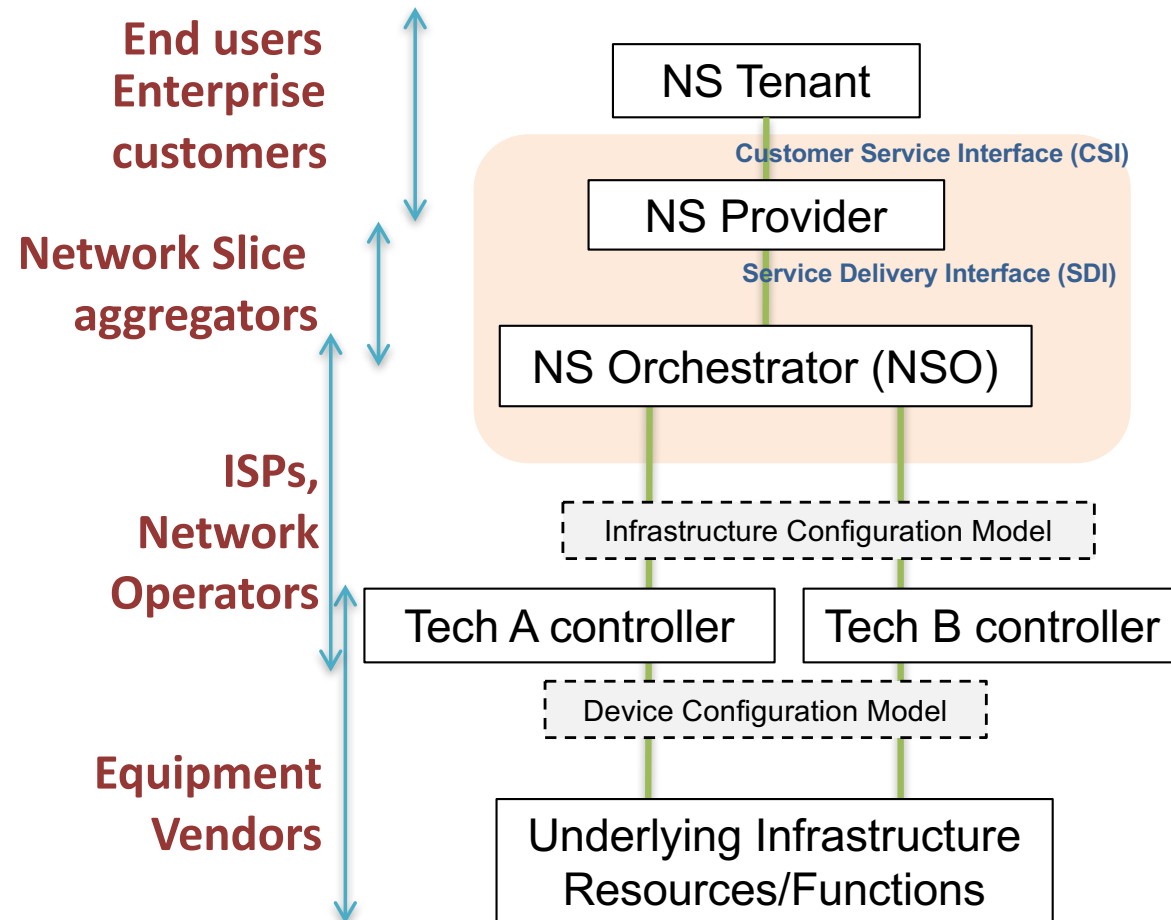

In pursuit of slices

- 5G Operators and providers
- Importance on 5GC, 5G-NR slicing
- E2E slicing trials and PoCs

Focus

- Automation of slices
- Multi supplier integration
- SDN + NFV as key enabler
- Standardization ??
- Nested slicing

Vendor's Perspective

- Access
 - 5G-NR for radio, or edge compute, fog compute
- Transport
 - Flexible Ethernet (FlexE) provides network slicing isolation
 - Network protocols, like SR or EVPN for service bearer information
 - Programmability/SDN Controller enhancements (e.g. ACTN)
- Core
 - Multi-Access Edge Computing to reduce service latency,
 - Service based architecture of 5G core functions

5G Slicing Association: including Huawei, Tencent, Germany's Deutsche Telekom, Digital Domain and Volkswagen.

<https://www.gsma.com/futurenetworks/presentation/mwca17-5g-seminars/>

Operator's View M-CORD E2E 5G/LTE slices



CORD: Central Office Re-architected as Data Center

Core Slicing

- Partially shared or isolated slices.
- Compute, storage VNFs
- Manager and Orchestration
- Per slice user and flow management
- SDN control

Ran Slicing

- Time-frequency-space blocks (RBS in LTE)
- Downlink & uplink scheduling
- Admission control policy
- Spectrum usage
- Dual carrier policy
- Link aggregation policy
- SON policy
- Dynamic Mapping of RBS to slices
- Asset control. Capability management
- Flow, User

Transport Slicing

- QoS Shaping, Isolation, Security
- Network Slice as a Service through Service Operating System.
- Link, Port, Forwarders, Bandwidth
- SDN control



- Both Core and RAN is disaggregated,
- RAN Controller provides RAN slicing
- The mobile CORD open reference solution for 5G

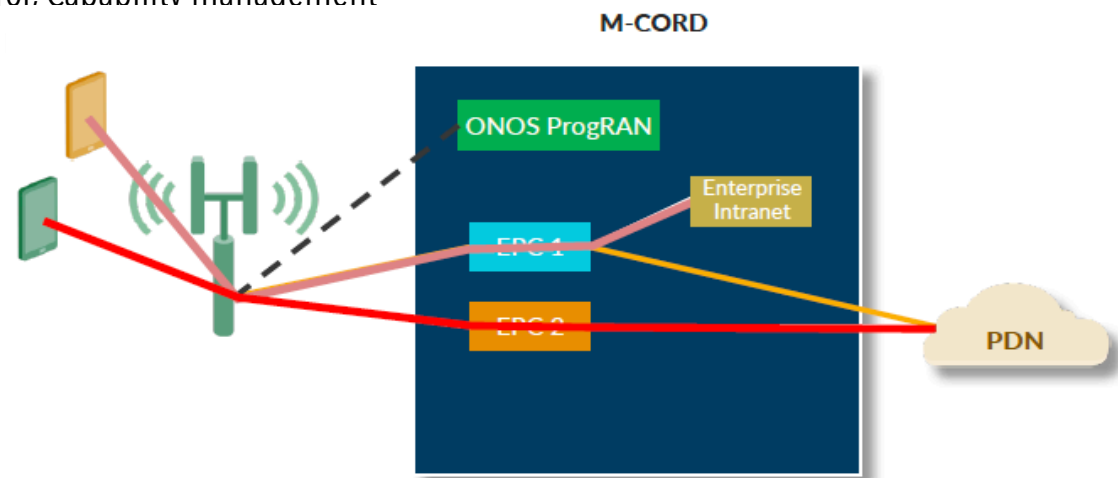

Ref: <https://drive.google.com/drive/folders/OB0zAHVUI24dQLW1ncFFKUWhwdWM>

Slicing Vision: Forward looking scenarios (Multi-slice use case)

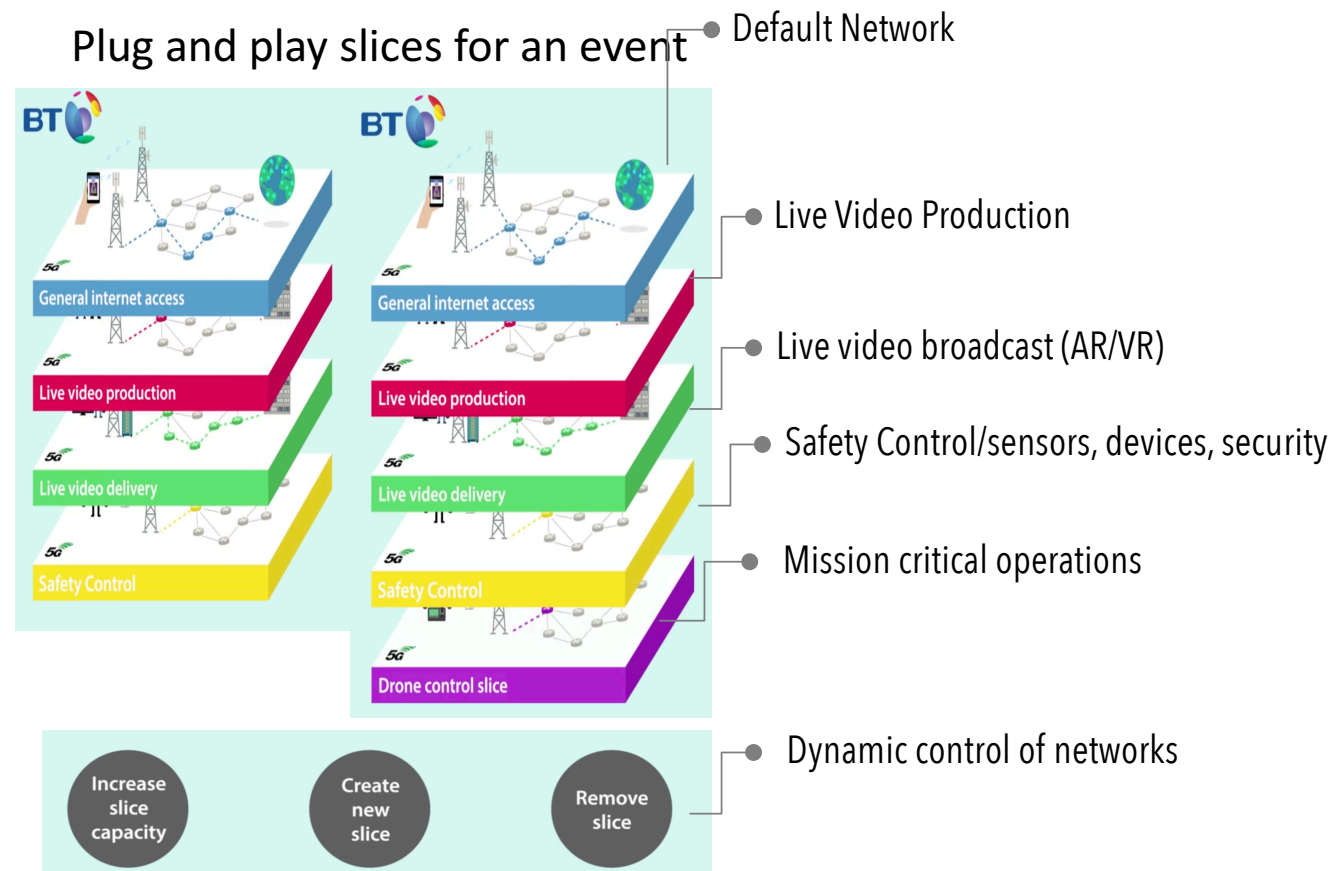

<https://5g.co.uk/news/bt-and-nokia-collaborate-on-live-vr-broadcasts-over-5g/4134/>
<https://5g.co.uk/news/bt-huawei-team-up-network-slicing/4142/>

Operator's View: Forward looking scenarios



Several showcases at MWC/SDN-MPLS

- Connected V2X usecase
 - <https://hellofuture.orange.com/en/network-slicing-innovative-5g-connectivity-connected-vehicles/>
- Interactive AR/VR Slice
 - <http://telecoms.com/intelligence/huawei-and-telefonica-jointly-demonstrate-the-industrys-first-5g-slicing-based-interactive-vr-service/>
- M-CORD slices
 - <https://opencord.org/wp-content/uploads/2018/01/Network-Slicing-and-Private-LTE.pdf>

IoT use case (IT and OT integration)

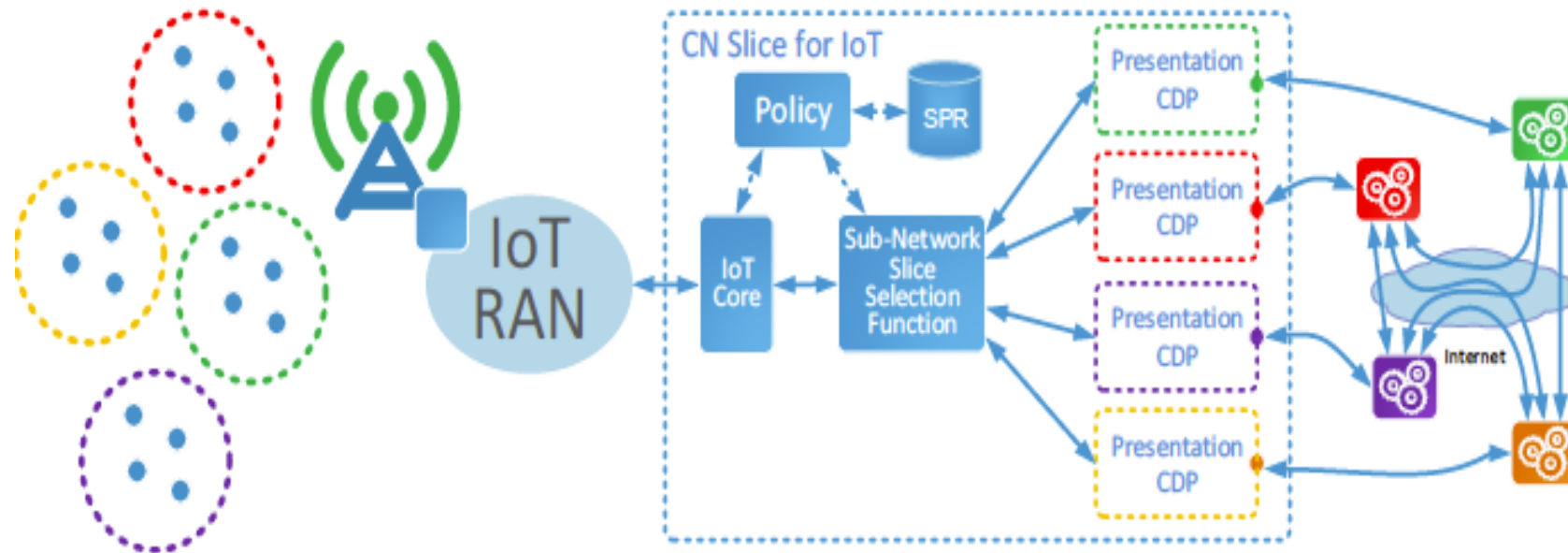

- Network slicing solves the problem of directing traffic from enterprise-owned devices to the enterprises themselves
- Policies in virtualized core

MWC Americas 2017, Future Networks seminar, Cisco

<https://www.gsma.com/futurenetworks/presentation/mwca17-5g-seminars/>

Industry Perceived Network slice challenges



1. **Non-stand alone solutions:** In order to eliminate complexity, standalone version of 5G is needed. 5G services for sophisticated requirements need 5G core network features.
2. **Standardization:** what to standardize and what no while balancing with innovation. Too many SDOs and alliances working with different motivations.
3. **Rules on net neutrality:** slices provide preferential treatment to certain services, operators are prevented from doing this.
4. **Long-term and diverse use cases:** true incentives for use cases such as V2X, remote health care, live AR/VR... (not urgent requirements).
5. **Inter-domain asset sharing:** Automation of resource management across other administrative domains.
6. **Hard-slicing paradigm shift:** True potential with full control at the lowest level – PHY and MAC.

Source: <https://inform.tmforum.org/wp-content/uploads/2017/06/5G-slicing-challenges.png>,

Survey: *Trend Analysisreport 5G: Is platform the killer use case?*

Contents List

1. Key Slicing concepts and history
2. Slicing Key Characteristics & Usage scenarios
3. Multi-Doman Network Function Virtualisation
4. Standard Organization activities: NGMN, ITU-T, ONF, 3GPP, ETSI, BBF, IETF
5. Review of Research projects and results in network and cloud slicing
6. Open Source Orchestrators
7. Industrial perspective on Network Slicing
8. Review of industry Use Cases
9. Network Slicing Challenges
10. Concluding remarks of Network Slicing
11. Acknowledgements & References

Use case classifications

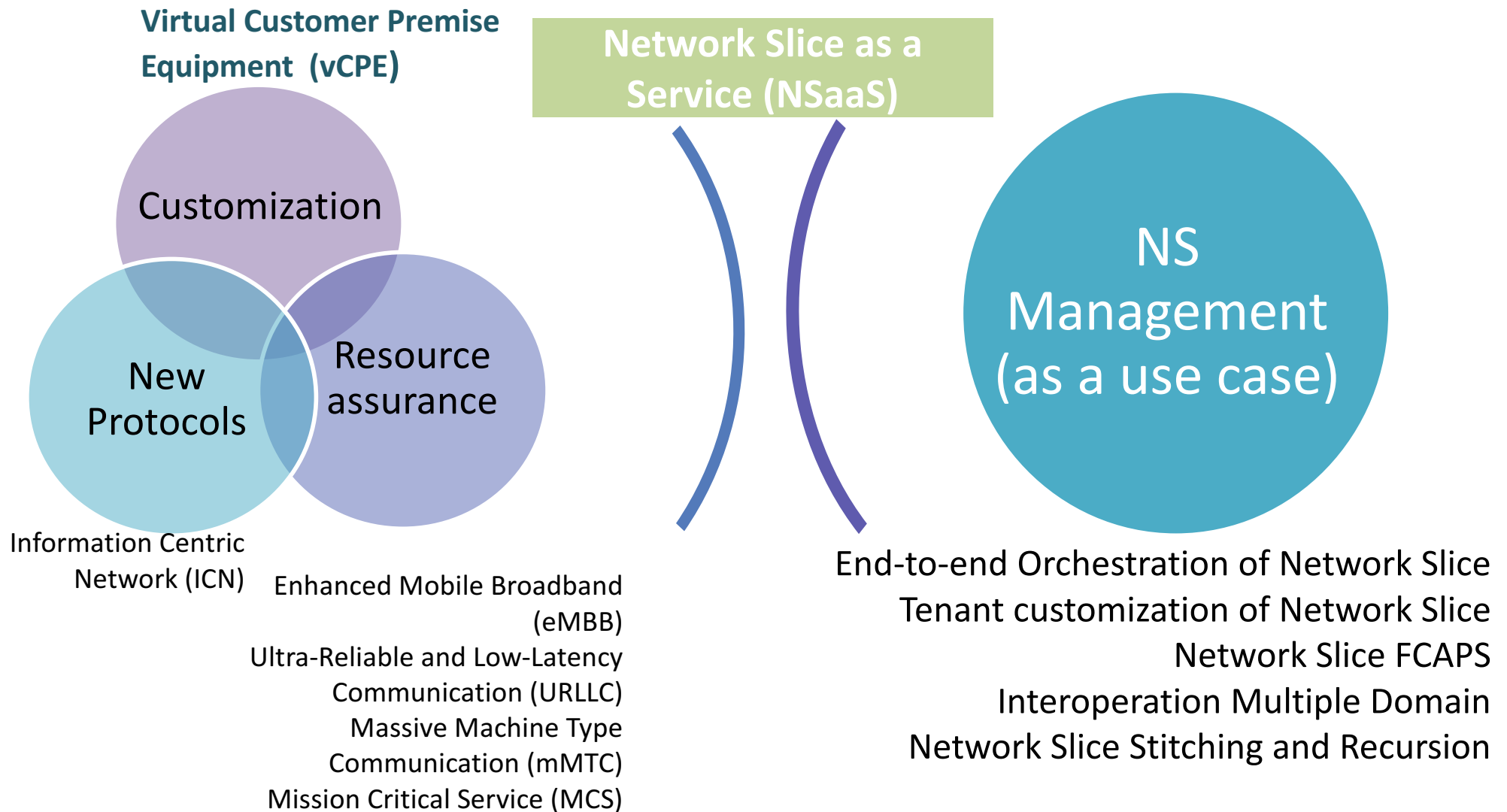

1. Service Customization - vCPE

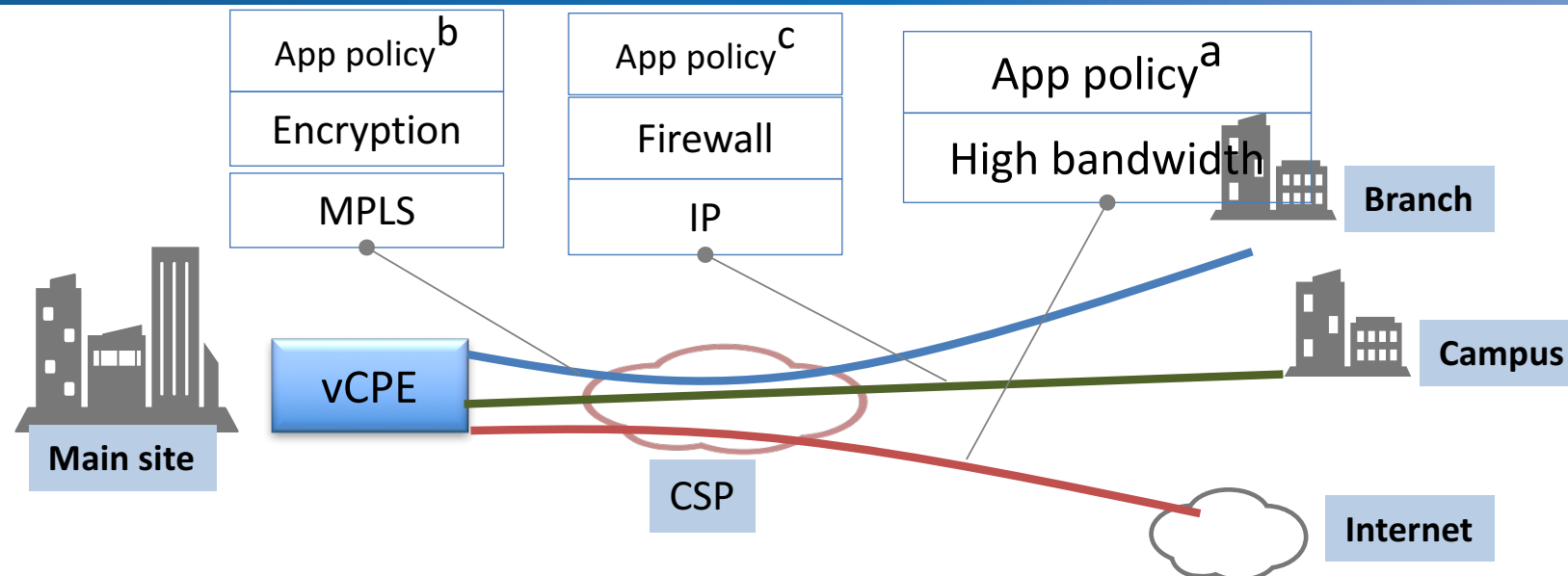

Different connectivity profile, Different customers, varying service function placements

vCPE Requirements:

1. Manage transport network requirements
2. Different requirements and L4-L7
3. Varying Policies for different application permissions
4. Different customers – customization

vCPE in a network Slice:

1. Provide a vCPE manager network function that describes a service graph
2. Fill requirements for different paths in graphs.

2. Resource Assurance – Ultra Reliable low latency

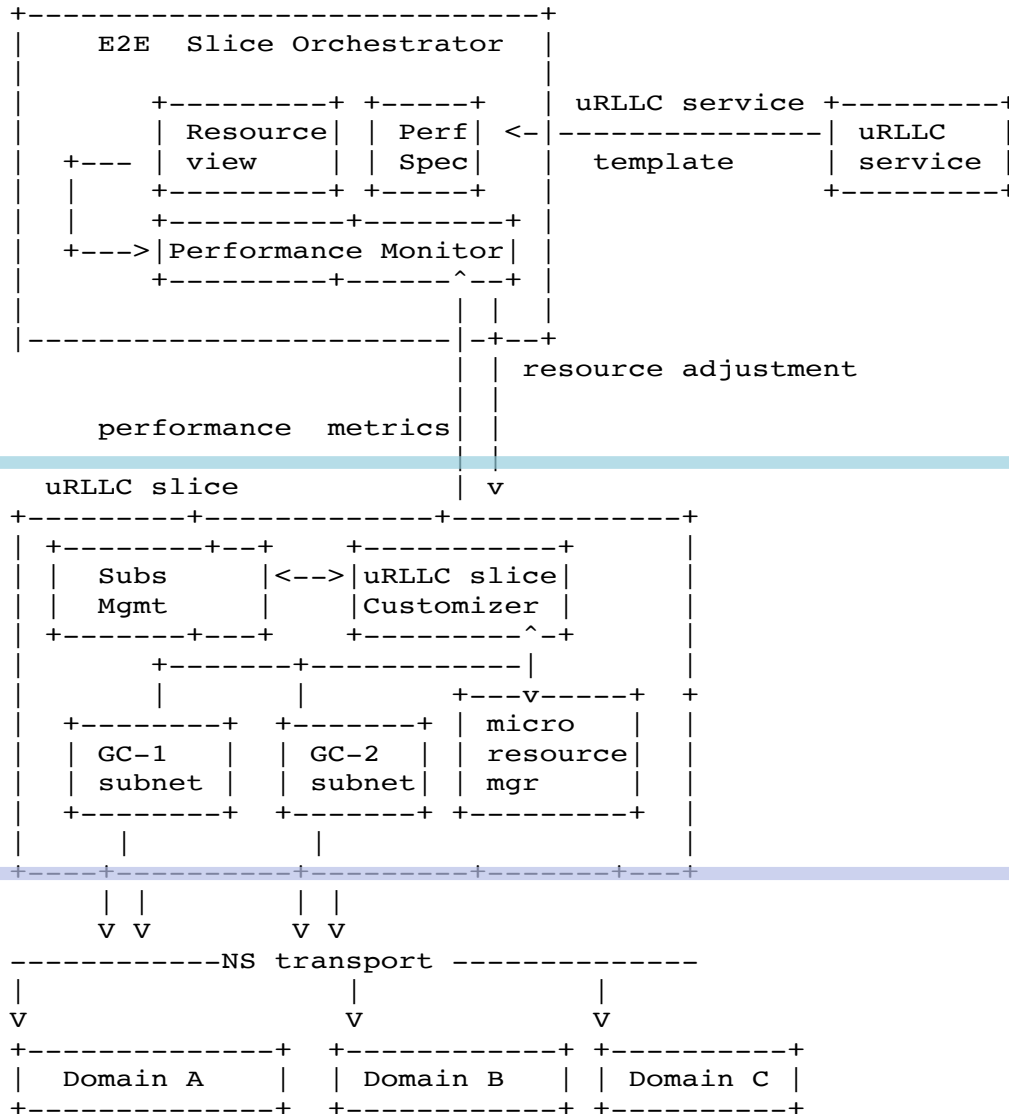

Scenarios (advanced)

1. Remote Industry Operations and control.
2. V2X
3. Remote health

Control Loops

1. Continuous metrics collection
2. Autonomous resource mgmt with in a slice

Transport

1. Reliable connectivity and high-availability.
2. Network Functions close to Access

3. Hard Slice Type Example - Mission Critical Services

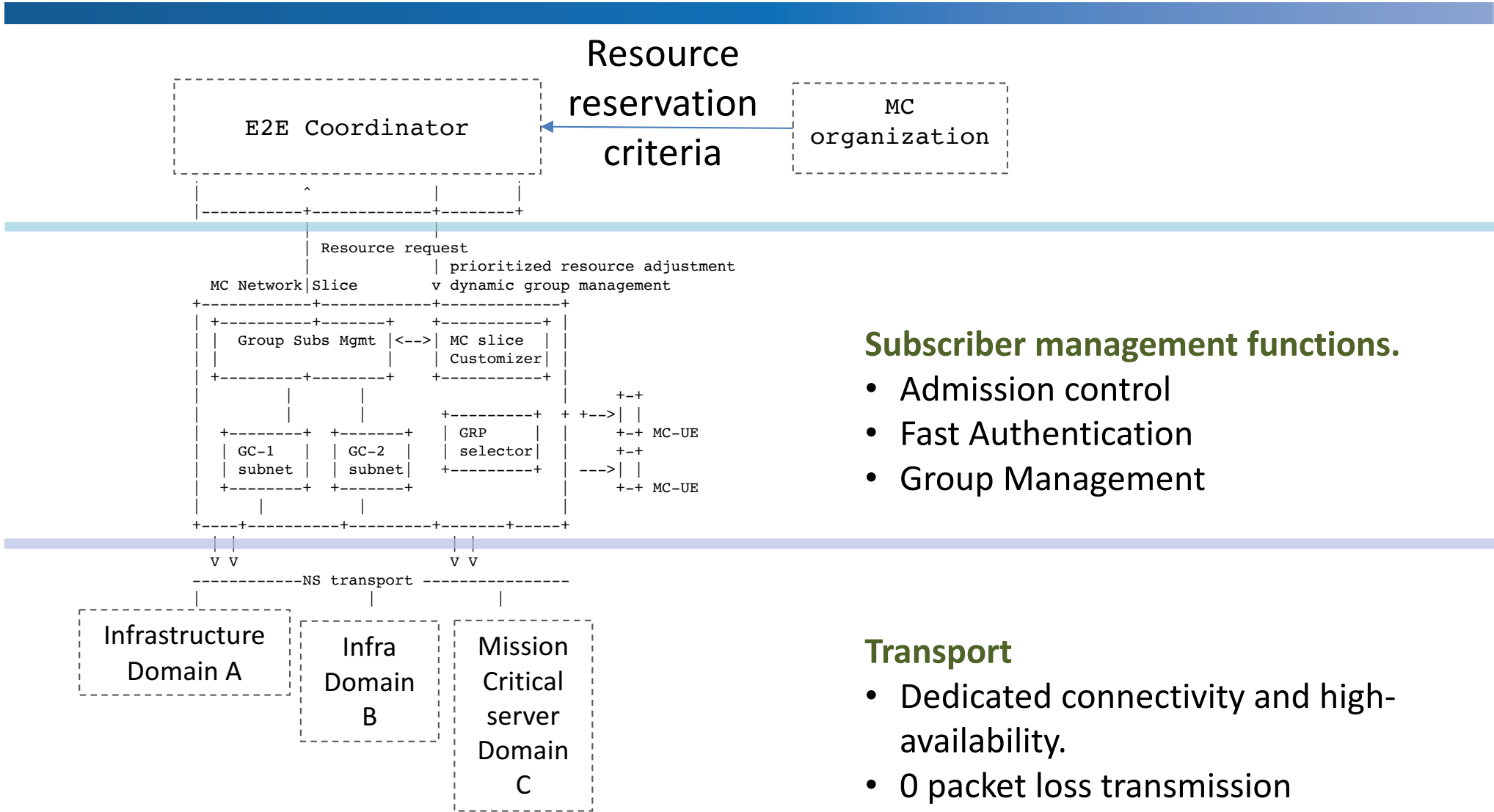

Subscriber management functions.

- Admission control
- Fast Authentication
- Group Management

Transport

- Dedicated connectivity and high-availability.
- 0 packet loss transmission

4. New Technology Type Use Case - Information Centric Network (ICN)

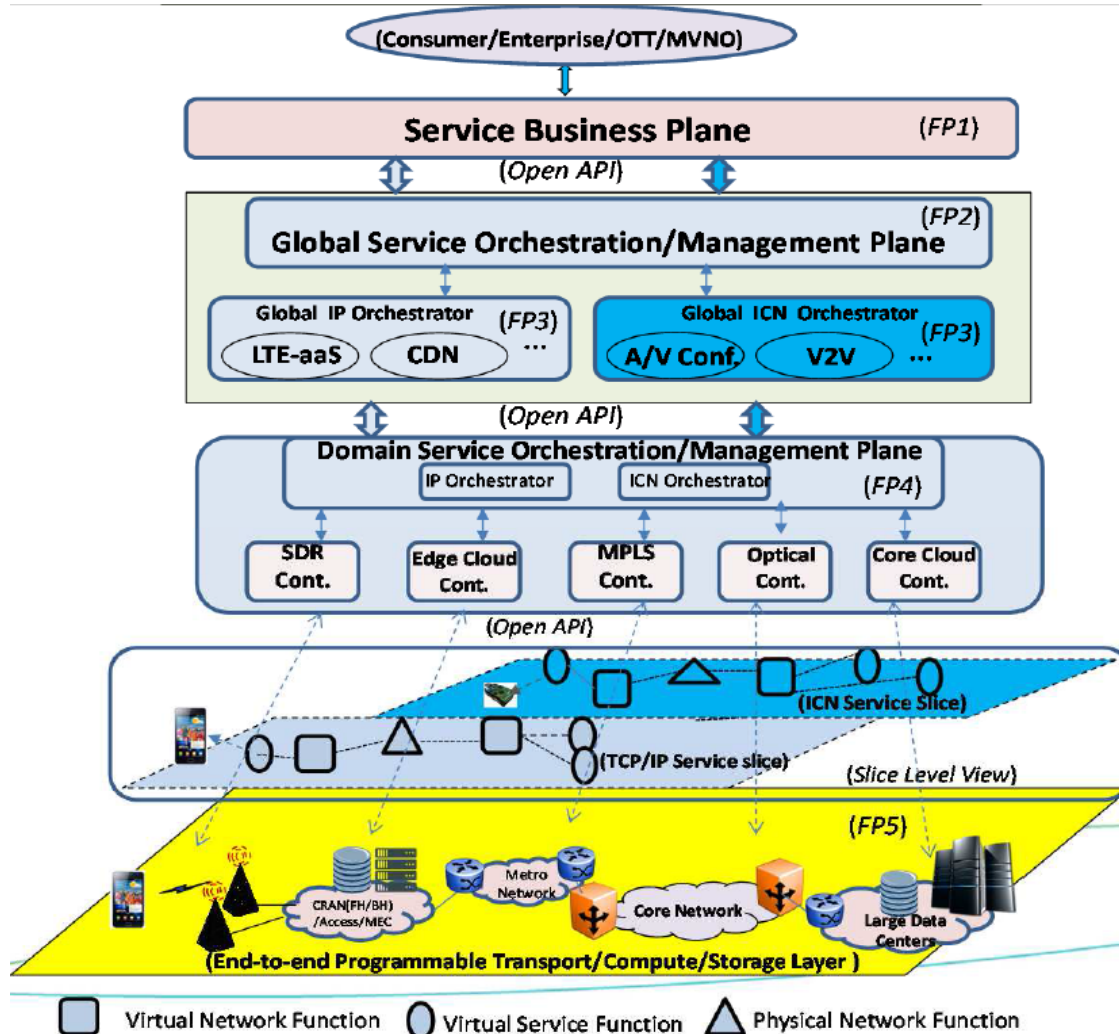

- ICN is a non-IP paradigm based on name-based routing
- ICN based services can be offered as a network slice in parallel with traditional IP based services

Transport

- Proper resource isolation between ICN and other IP based slices

“Realizing ICN as a Network Slice for Mobile Data Distribution”, IETF 98 Network Slicing Side Meeting

Elicited 4 KEY Requirements

Req3: Performance Guarantee and Isolation

- 4. OAM , Status monitoring, resource tracking, etc..**
- 1. Expose network resources**

Tenants



Req1: Slicing Resource & Requirement Description

- 1. Describe slicing requirement**
e.g. network slice with at most 10 ms one-way E2E latency



Req2: Cross-Domain Coordination

- 3. Coordinate to construct the network Slice**

e.g. AN 2ms; TNI 2ms; TNII 4ms; CN 2ms

Req1: Slicing Resource & Requirement Description

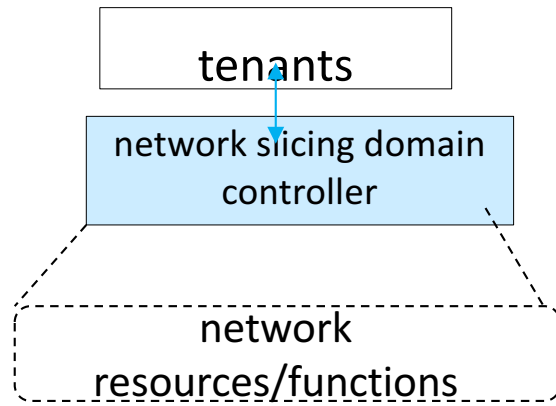

1. Performance metrics
2. Protection requirements
3. Isolation constraints
4. Path restriction (e.g., must pass through some points for security)
5. High-availability guidelines (e.g., URLLC service restoration within 10ms, 100ms, or 1 second)

▣ Related Work in IETF

YANG Data Models

- L2SM, L3SM, EVPN, etc.. technology-specific

Connectivity Provisioning Profile (CPP) Template

- (Traffic) objectives of traffic engineering functions and service management functions

Traffic Engineering Architecture and Signaling (TEAS) base & TEAS

- Abstract topologies with traffic engineering constraints
- Templates for links or resources

- 1) Lack of resource abstraction and management on Layer 3+ (e.g., routing table)
- 2) Specification of advanced service functions to be invoked and their invocation order

Req2: Cross-Domain Coordination

A common platform for different providers/administrators ?

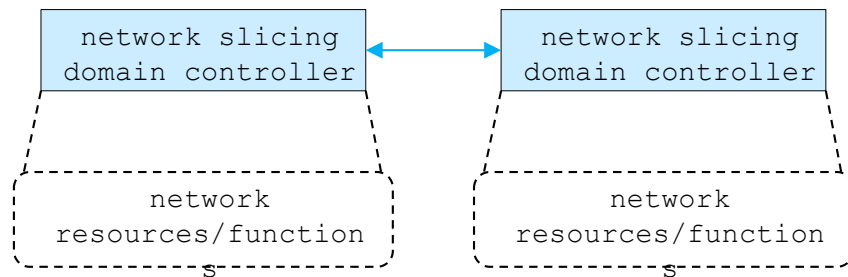

- Network slice resource coordination (e.g., 10ms latency E2E slice → 2ms in RAN + 4ms in TN1+ 2ms in TN2 + 2ms in CN)
- Configuration information coordination (e.g. VLAN ID, remote IP address, physical port ID)
- Other coordination (e.g., notify TN about the location of attachment point)

□ Related Work in IETF

Abstraction and Control of TE Networks (ACTN)

Multi-domain coordination in Traffic Engineering (TE) network through a (hierarchical) Multi-Domain Service Coordinator (MDSC)

A Generic Autonomic Signaling Protocol (GRASP)

Autonomic negotiation protocol in underlying infrastructure layer

connectivity provision negotiation protocol (CPNP)

Dynamic negotiation protocol for connectivity provisioning (and other service-specific) parameters between customer and provider

- 1) A flat cross-domain coordination solution
- 2) Extension on NS specific behaviors and objects

Req3: Performance Guarantee and Isolation

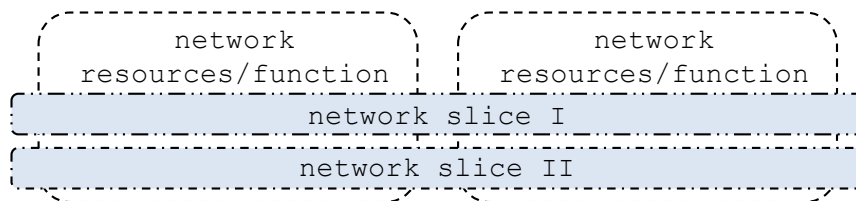

- performance isolation
- secure isolation
- management isolation

□ Related Work in IETF

Virtual Private Network (VPN)	Network Virtualization Overlays	Segment Routing (SR)	Flexible Ethernet (FlexE)	Deterministic Networking (DetNet)	Resource Reservation Protocol-Traffic Engineering (RSVP-TE)
Logically separated routing/bridging regions	Layer 2/3 service for virtual networks enabling multi-tenancy	SR-based LSPs provide TE features	Complete decoupling of MAC layer and physical layer	Deterministic data paths with extremely low packet loss rates, low delay variation and assured maximum E2E delivery latency over Layer 2 and Layer 3	Signal protocol to establish E2E TE LSP with bandwidth reservation

- 1) Tighter coupling between underlay and overlay
- 2) Enhancement to data plane and control plane

Req4 : Network Slicing OAM

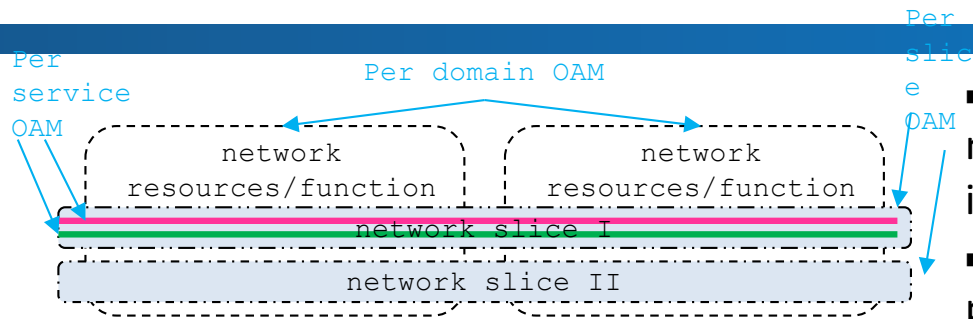

- Operations: keeping all resources associated with a network slice up and running (e.g., monitoring, identifying problems to a slice operator)
- Administration: tracking resource usage within the provider network as well as within a slice
- Maintenance: facilitate repairs and upgrades within a slice without any impact to other slices. Also involves corrective and preventive measures (e.g., adjusting configuration)

□ Related Work in IETF

Technology-Specific OAM tools [RFC7276]

IP Ping (IPv4/IPv6), IP Traceroute(IPv4/IPv6), BFD (generic), MPLS OAM (MPLS), MPLS-TP OAM (MPLS-TP), Pseudowire OAM (Pseudowire), OWAMP and TWAMP (IPv4/IPv6), TRILLA OAM (TRILL)

Overlay OAM

A generic OAM header for overlay network OAM [I-D.ooamdt-rtgwg-ooam-header]

Service Function Chain (SFC) OAM

Service Function Component
Service Function Chain Component:
Classifier Component: test classifiers (mapping flows to service chains)

Customized granularity NS OAM

→ Information Model - Descriptors

- A precise description of the resources

Connectivity

- Topology
 - Node
 - Link
- Virtual Topology
- Bandwidth
- ...

Computing/Storage

- Bare Metal
- VMs
- Containers
- MicroServices
- Storage
- Other forms of Computing infrastructure
- ...

Service Functions

- PNF/VNF including
 - Monitoring
 - Configuration
 - QoS
 - NAT
 - DHCP
 - Firewall
 - CDNs
 - Customer SDN-Controllers/ slice manager
 -

→ a cross-domain approach

- Cross-domain caused by integration of network and computing
 - A customer wants a Turn-Key solution

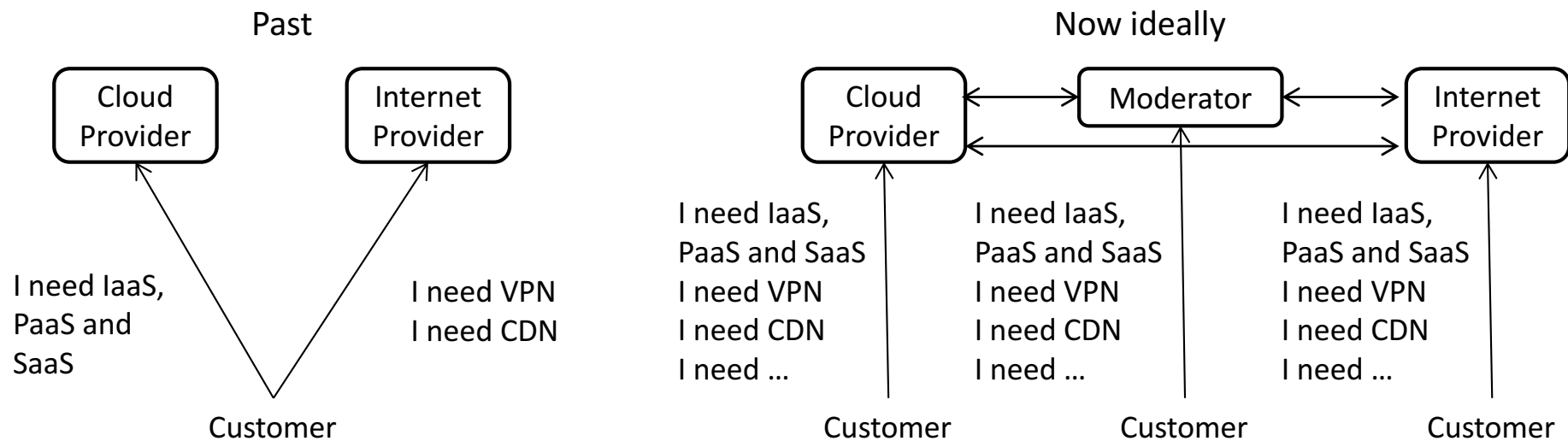

→ a cross-domain approach

- Cross-domain caused by integration of network and computing
 - A customer wants a Turn-Key Solution

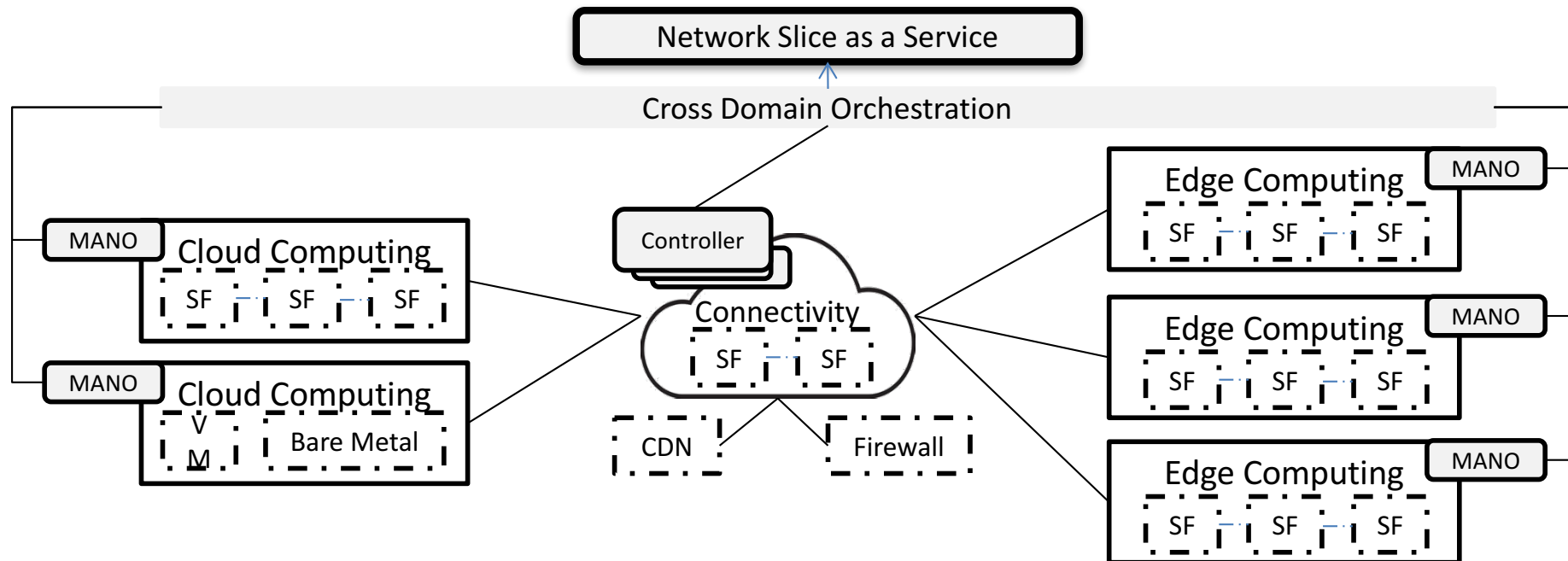

Contents List

1. Key Slicing concepts and history
2. Slicing Key Characteristics & Usage scenarios & Value Chain
3. Multi-Domain Network Function Virtualisation
4. Review of Research projects and results in network and cloud slicing
5. Open Source Orchestrators
6. Standard Organization activities: NGMN, ITU-T, ONF, 3GPP, ETSI, BBF, IETF
7. Industrial perspective on Network Slicing
8. Review of industry Use Cases
9. Network Slicing Challenges
10. Concluding remarks of Network Slicing
11. Acknowledgements & References

Network Slicing Challenges

References

- “Towards 5G Network Slicing - Motivations and Challenges” Alex Galis – UCL, Chih-Lin I-Chin, China Mobile- IEEE 5G Tech Focus, Volume 1, Number 1, March 2017- <http://5g.ieee.org/tech-focus/march-2017#networkslicing>
- “Network Slicing - Revised Problem Statement” - draft-galis-netslices-revised-problem-statement-01, Alex Galis & all, July 2017
- “Perspectives on Network Slicing – Towards the New ‘Bread and Butter’ of Networking and Servicing” Prof. Alex Galis – January 2018 <https://sdn.ieee.org/newsletter/january-2018/perspectives-on-network-slicing-towards-the-new-bread-and-butter-of-networking-and-servicing>

Network Slicing Reference Architecture

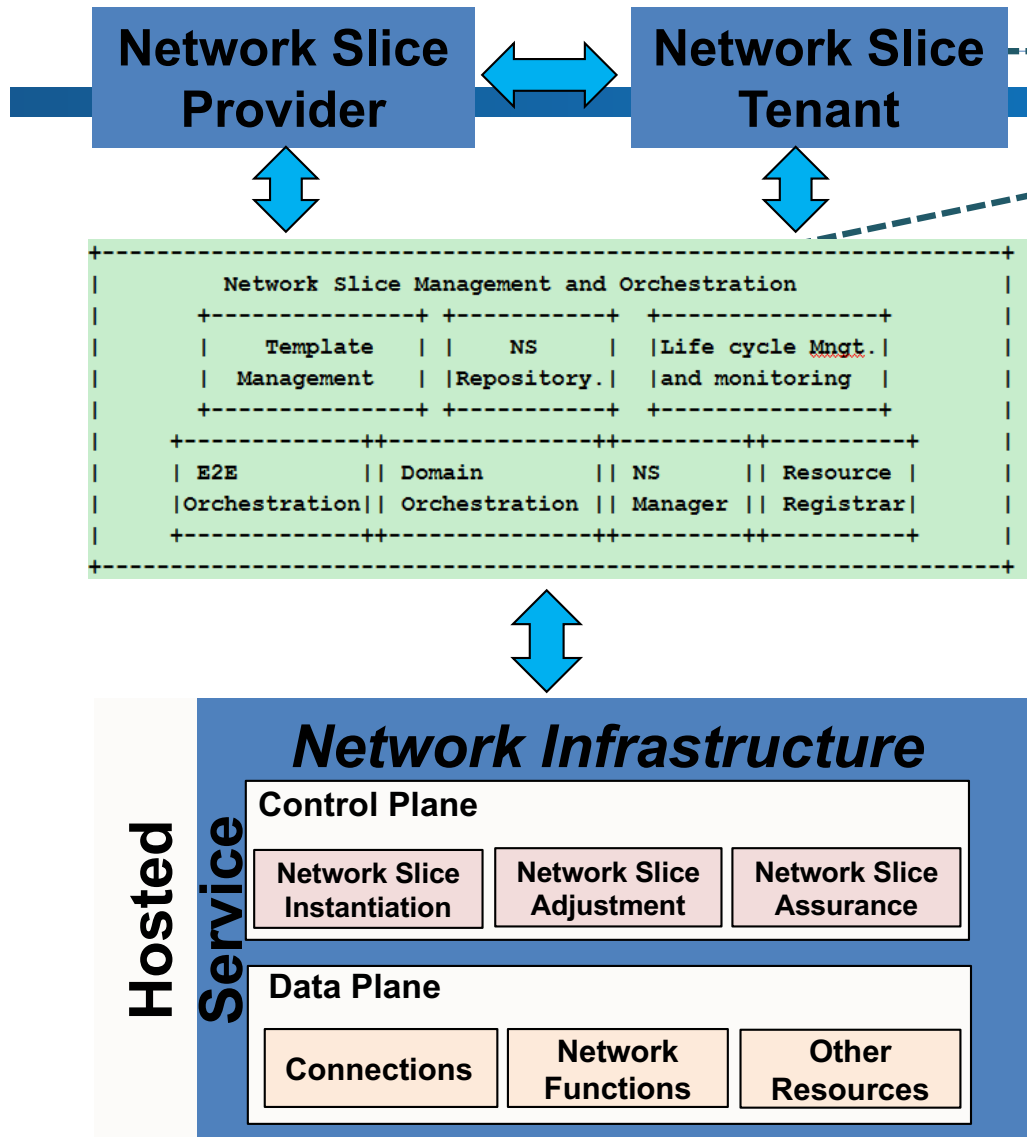

Challenges

Cross-Domain Coordination

- Service/data model & mapping in a single domain and Cross-Domain Coordination
- Slice stitching / composition in a single domain and Cross-Domain Coordination

Network Slicing Management

- Uniform Network Slice life cycle management
- Network Slice Monitoring and Discovery
- Autonomic slice management and operation
- E2E Network Orchestration
- Realisation of NS Characteristics

Performance Guarantee and Isolation

- Guarantees for network slice isolation

Slicing Resource & Requirement

- Uniform Reference Template
- Capability exposure and APIs
- Deployment and Economic Challenges

Network Slice Life Cycle Management; E2E Network Orchestration



NS Life Cycle Management: (1) The management plane creates the grouping of network resources (physical, virtual, or a combination thereof), it connects with the physical and virtual network and service functions, and it instantiates all of the network and service functions assigned to the slice. (2) Template/NS repository assists life cycle management; (3) Resource Registrar manages exposed network infrastructure capabilities; (4) NS Manager oversees individual slice (with capability exposure to NS Tenant).

E2E Orchestration (1) Coordination of any number of inter-related resources in a number of subordinate domains, and assurance of transactional integrity as part of the triggering process; (2) **Autonomic control of slice life cycle management**, including concatenation of slices in each segment of the infrastructure (in data, control, and management planes); (3) **Autonomic coordination and triggering of slice elasticity and placement**; (4) **Coordination and (re)-configuration of resources** by taking over the control of all the network functions.

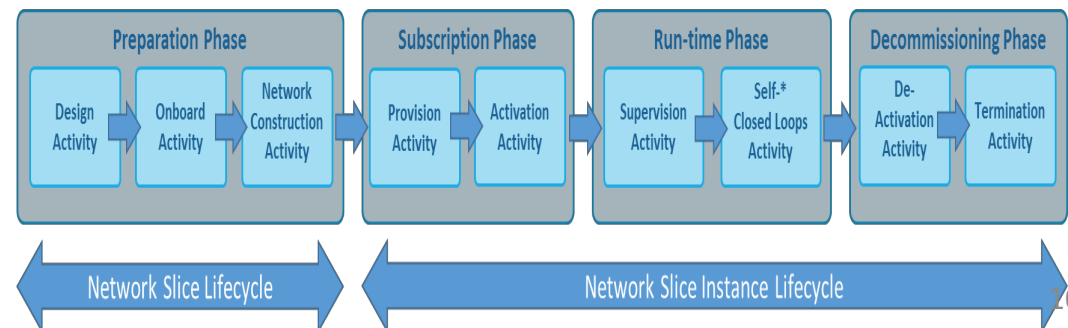
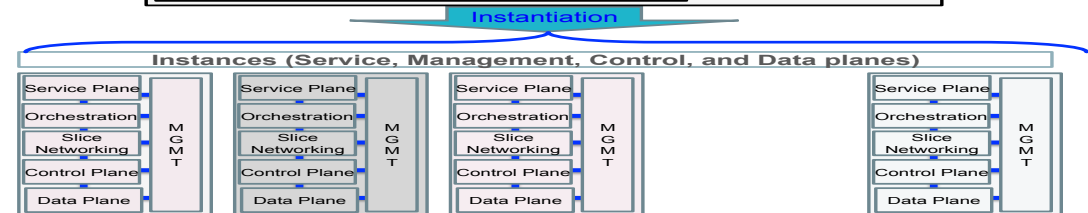
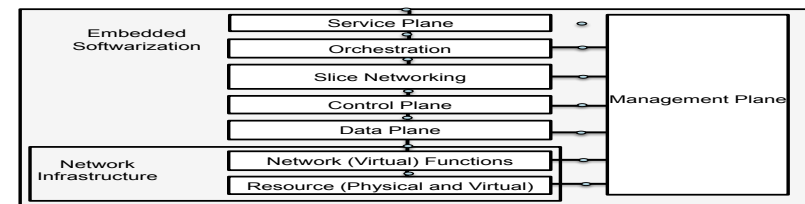

Monitoring and Discovery; Autonomic Slice Management



Monitoring and Discovery: (1) Monitoring Subsystem is responsible for **monitoring continuously the state all components of a NS**; (2) Monitoring Subsystem receives the detailed service monitoring requests with references to resource allocation and Network functions instances in a NS. (3) **Discovery and monitoring probes are needed of all NS components** and NS itself and for dynamic discovery of service with function instances and their capability.

Autonomic slice management: (1) Network slice is a dynamic entity with autonomic characteristics of its lifecycle and operations. (2) The problem of allocation of resources between slices combined with real-time optimization of slice operations can only be solved by continuous autonomic monitoring of slice performance and making continuous autonomic adaptations of the resources allocated to them.

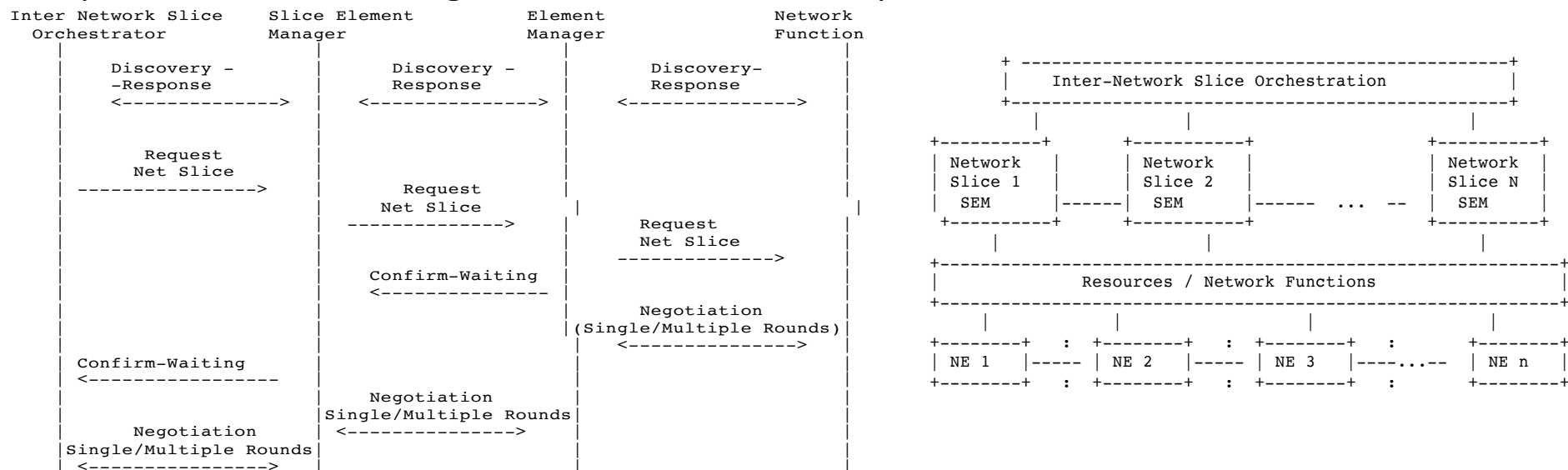

Service Mapping Single Domain / Cross-Domain; Slice stitching; Guarantees for isolation



Service / data model & mapping : (1) service mapping enables on-demand processing anywhere in the physically distributed network, with dynamic and fine granular service (re)-provisioning; (2) It includes a slice-aware information model based on necessary connectivity, storage, compute resources, network functions, capabilities exposed and service elements.

Slice stitching : The stitching of slices is an operation that modifies functionality of an existing slice by adding and merging functions of another slice (i.e. enhancing control plane properties by functions defined in another slice template). Stitching of slices is used to enrich slice services: (1) Slice stitching operations are supported by uniform slice descriptors; (2) Efficient stitching/ decomposition (vertically, horizontally, vertically + horizontally).

Guarantees for Isolation: (1) guaranteed level of service, according to a negotiated SLA between the customer and the slice provider; (2) NS must be isolated at service level (e.g., one slice must not impact on the level of service of the other slices, even if sharing resources); isolated at data/control / management level, even if sharing resources; (3) exclusive control and/or management interfaces, enabling the deployment of different logical network slices over shared resources.

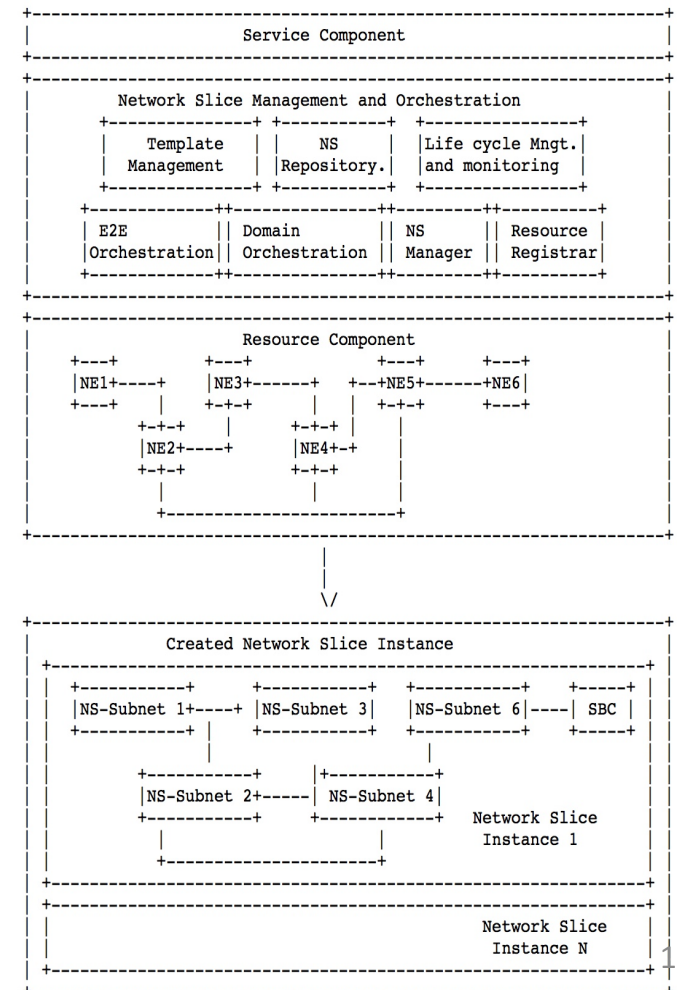

Uniform Reference Model; Slice Templates; Slice Element Manager and Capability exposure – APIs



Uniform Reference Model: Has (1) Description of all of the functional elements and functional roles required for network slicing; (2) boundaries between the basic network slice operations (creation, management, exposure, consumption); (3) Normalize nomenclature and descriptive / prescriptive definitions.

Slice Templates: Contains (1) Description of Service Instance Components; (2) Description of Network Functions Instance Components; (3) Description of Resource (connectivity, compute, storage); (4) Description connectivity, compute, storage resources; (5) Description of Slice Element Manager and Capability exposure component.

Slice Element Manager & Capability exposure – APIs: Has (1) Description of **exclusive control and/or management interfaces and capabilities exposed for a network slice**, enabling the deployment of different logical network slices over shared resources; (2) **Description of the Slice Element Manager** which guarantees a level of service, according to a negotiated SLA between the customer and the slice provider.

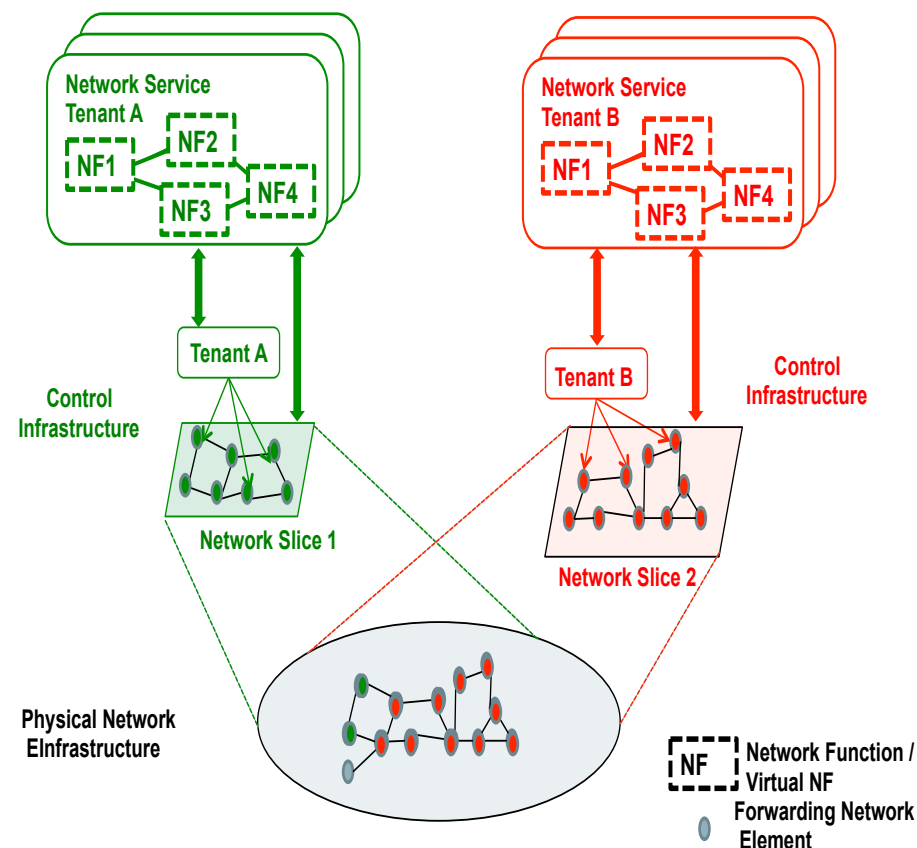

Challenges in Realising Network Slicing Capabilities (I)

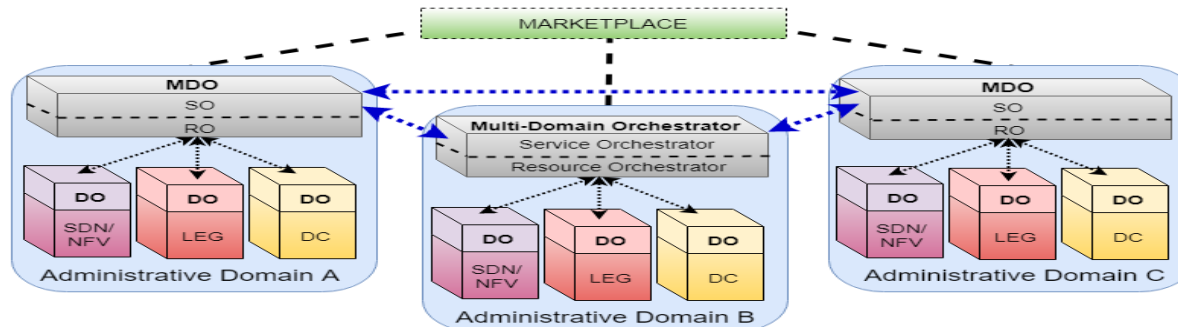

Network Slicing Service Mapping: creating an efficient service mapping model binding across network slicing; specifying policies and methods to realize diverse service requirements without re-engineering the infrastructure

Network Slicing Recursion: Recursion, namely methods for NS segmentation allowing a slicing hierarchy with parent–child relationships

Customized security per slice: In any shared infrastructure, security is a key element to guarantee proper operation, and especially a fair share of resources to each user including Resource isolation and allocation policy at different levels and Isolation of network service management for multiple tenants

Network Slices Reliability: Maintaining the reliability of a network slice instance, which is being terminated, or after resource changes

Network Slices Reliability: Maintaining the reliability of a network slice instance, which is being terminated, or after resource changes

Flexible Radio Access Network (RAN) slicing: RAN slicing targeting flexible customization and multiplexing over disaggregated RAN infrastructures agreement (SLA) with a tenant

Challenges in Realising Network Slicing Capabilities (II)



Per-tenant Policy Management: In a multi-tenant, multi-slice end-to-end hosting and networking scenario, closed-loop automation requires both per-tenant policies, as well as the network operator's own. Per-tenant policies would be set to limit compute, storage and network resource usage, block the execution of unauthorized operations, trigger actions including scaling, healing, and topology reconfiguration to meet the service-level agreement (SLA) with a tenant

Network Slicing Scalability: Scalability: In order to partition network resources in a scalable manner, it is required to clearly define to what extent slice customers can be accommodated or not on a given slice. The application of different SLAs on the offered capabilities of management, control and customization of slices will directly impact the scalability issue.

Uniform Slice lifecycle management : Slice lifecycle management including creation, activation / deactivation, protection, elasticity, extensibility, safety, and sizing of the slicing model per network and per network cloud for slices in access, core and transport networks; for slices in data centres/clouds/

Network Slicing Optimisation: namely methods for automatic selection of network resources for NS; global resource views; global energy views; Network Slice deployment based on global resource and energy efficiency

Network Slicing Dimensioning: Over-dimensioning has been the normal way in the past for avoiding any kind of congestion. With slicing the traffic sources and destinations become much less predictable, if at all. Appropriate planning, dimensioning and enforcement are needed to make sustainable the transition to this new form of service .

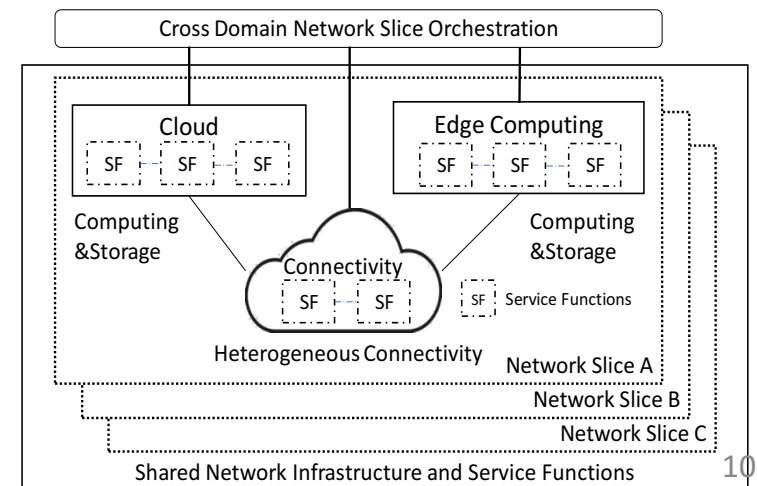

Deployment Options: There are architectural, engineering, performance, flexibility and service agility without disruption challenges in terms support of many next-generation services in a NS enable infrastructure. In terms of deployment options an operator could deploy a single multi-service network, with a shared physical layer supporting a shared functional layer. Alternatively, the operator could deploy separate physical sub-networks, each with their own physical resource layer and functional layer on top of that; Or the operator could deploy discrete virtual networks, built on one shared physical resource layer, with multiple functional layers dedicated to each application or service type.

Economy of Scale in Slicing: The benefits of slicing grow as the number of service types that you are trying to launch grows. In addition significant investment is needed in automation to be able to do this at scale, otherwise the complexity and operational challenges are likely to mount up. It's key that the rest of the organisation gears up to support this ambition – development, delivery, marketing, operations and so on - otherwise the operator won't be able to exploit the technology commercially.

Service Diversity: the key challenge is how to support and operate different kind of services with very distinct needs onto the same infrastructure. One practical approach is to position segregated services on specialized partitions, designed and optimized for the type of service to be provided.

Vertical Customers: Interaction with the vertical customers: Proper abstractions and templates have to be defined for ensuring the provision of a consistent service portfolio and their integration with the internal network management and orchestration.

Contents List

1. Key Slicing concepts and history
2. Slicing Key Characteristics & Usage scenarios & Value Chain
3. Multi-Domain Network Function Virtualisation
4. Review of Research projects and results in network and cloud slicing
5. Open Source Orchestrators
6. Standard Organization activities: NGMN, ITU-T, ONF, 3GPP, ETSI, BBF, IETF
7. Industrial perspective on Network Slicing
8. Review of industry Use Cases
9. Network Slicing Challenges
10. Concluding remarks of Network Slicing
11. Acknowledgements & References

Concluding Remarks: Slicing



Key Values:

- Concurrent deployment of **multiple logical, self-contained and independent, shared or partitioned networks on a common infrastructure platform.**
- **Network Slicing has the ability to expose its capabilities.**
- Enable **dynamic multi-service support, many/multi-tenancy** and the integration means for vertical market players.
- **Network Slicing** simplifies the provisioning of services, manageability of networks and integration and operational challenges especially for supporting communication services.
- **Network operators/ ISP can exploit network slicing** for
 - reducing significantly operations expenditures, allowing also programmability necessary to enrich the offered tailored services.
 - means for network programmability to OTT providers and other market players without changing the physical infrastructure.
- **Considerably transform the networking perspective** by
 - abstracting, isolating, orchestrating and separating logical network behaviors from the underlying physical network resources.

Concluding Remarks: Overall Context

E2N Multi-Domain Orchestration
E2E coordination, conflict resolution, multi-domain information exchange

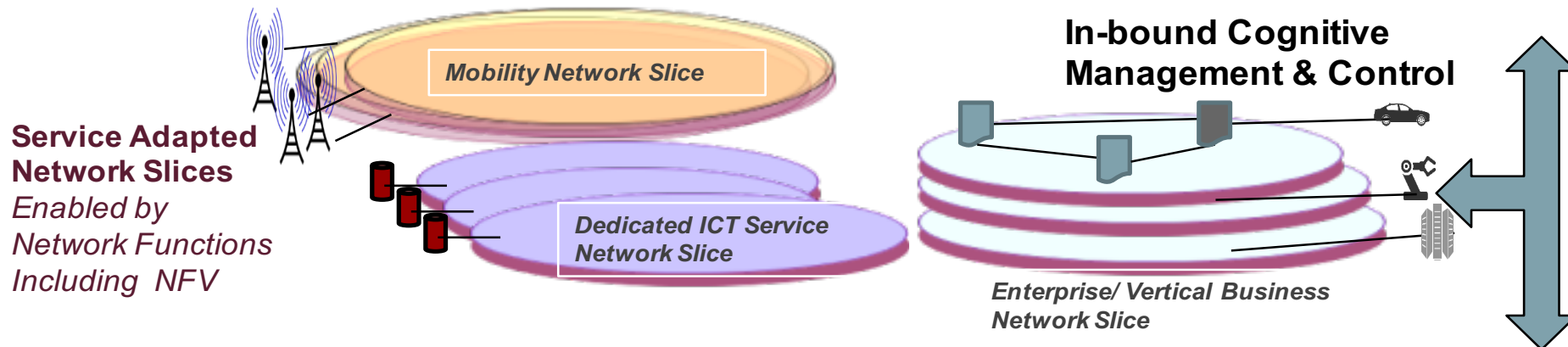

Smart Network Fabric: E2E Multi-Domain Network Operating System Facilities
Network Abstraction, Allocate (virtual) network resources, Maintain network state, Ensure network Reliability in a multi domain environment

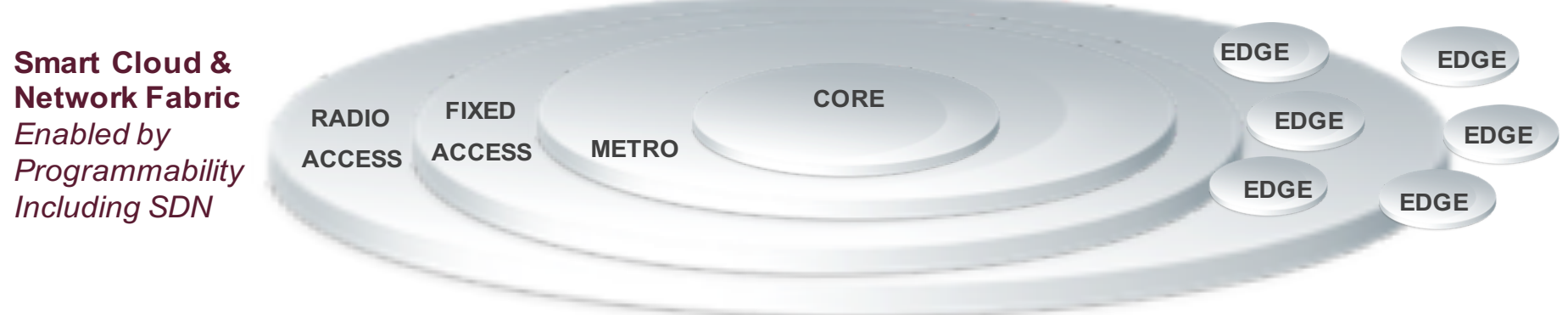

Acknowledgement

Projects:

1. **5GEX- H2020 project “Multi-domain Network Service Orchestration - <http://www.h2020-necos.eu>**
2. **NECOS – H2020 project “Novel Enablers for Cloud Slicing” - <http://www.h2020-necos.eu>**
3. **SONATA – H2020 project “Agile Service Development and Orchestration in 5G Virtualized Networks”- <http://sonata-nfv.eu>**

Comments & Review:

Francesco Tusa
(UCL; francesco.tusa@ucl.ac.uk)

Stuart Clayman
(UCL, s.clayman@ucl.ac.uk)

Luis Miguel Contreras Murillo
(Telefonica, luismiguel.contrerasmurillo@telefonica.com)

SDOs- References

ITU-T IMT2010/ SG13 (<http://www.itu.int/en/ITU-T/focusgroups/imt-2020/Pages/default.aspx>)

- Recommendation: Application of network softwarization to IMT-2020 (O-041) – 150 pp
- Framework for IMT-2020 overall network architecture (O-043) – 20 pp
- Network management framework for IMT-2020 (O-047) – 40 pp
- IMT-2020 network management requirements (O-046) - 25 pp

ETSI

- Network Operator Perspectives on NFV priorities for 5G- https://portal.etsi.org/NFV/NFV_White_Paper_5G.pdf
- Report on Net Slicing Support with ETSI NFV Architecture Framework http://www.etsi.org/deliver/etsi_gr/NFV-EVE/001_099/012/03.01.01_60/gr_NFV-EVE012v030101p.pdf
- ETSI GS NGP 001: "Next Generation Protocol (NGP); Scenario Definitions". <http://www.etsi.org/technologies-clusters/technologies/next-generation-protocols>

IETF

- NetSlices Architecture draft-geng-netslices-architecture-02
- Network Slicing - Revised Problem Statement draft-galis-netslices-revised-problem-statement-03
- NetSlices Management Architecture draft-geng-coms-architecture-01
- NetSlices Use Cases draft-netslices-usecases-01
- NetSlices Management Use cases draft-qiang-coms-use-cases-00
- NetSlices Information Model draft-qiang-coms-netslicing-information-model-02
- Autonomic NetSlicing draft-galis-anima-autonomic-slice-networking-04
- NetSlices Interconnections <https://tools.ietf.org/html/draft-defoy-coms-subnet-interconnection-03>

3GPP TR23.799 Study “Network Slicing’ (2016); SA5 TR 28.801 Study Item “Network Slicing” (2017)

ONF Recommendation TR-526 (2017) “Applying SDN architecture to Network Slicing”

NGMN White Paper on 5G 2016) -<https://www.ngmn.org/5g-white-paper/5g-white-paper.html>

BBF - Requirements / architecture of transport network slicing SD-406: End-to-End Network Slicing (2017)

5GPPP Association White Paper Views on 5G Architecture – Mark 2 – January 2018 <https://5g-ppp.eu/wp-content/uploads/2018/01/5G-PPP-5G-Architecture-White-Paper-Jan-2018-v2.0.pdf>

5G Slicing Association - Position Whitepaper : ‘5G Network Slicing for Cross Industry Digitization’ http://www-file.huawei.com/-/media/CORPORATE/PDF/white%20paper/5G-Network-Slicing-for-Cross-Industry-Digitization-Position-Paper.pdf?source=corp_comm

Additional References (I)

- Reshaping the mobile core network via function decomposition and network slicing for the 5G Era; 2016 IEEE Wireless Communications and Networking Conference; 2016; 10.1109/WCNC.2016.7564652
- Resource Slicing in Virtual Wireless Networks: A Survey; IEEE Transactions on Network and Service Management; 2016; 10.1109/TNSM.2016.2597295
- Service-oriented resource virtualization for evolving TDD networks towards 5G; 2016 IEEE Wireless Communications and Networking Conference; 2016; 10.1109/WCNC.2016.7565171
- Quality of service provision and capacity expansion through extended-DSA for 5G; 2016 European Conference on Networks and Communications (EuCNC); 2016; 10.1109/EuCNC.2016.7561032
- Enabling Campus Edge Computing Using GENI Racks and Mobile Resources; 2016 IEEE/ACM Symposium on Edge Computing (SEC); 2016; 10.1109/SEC.2016.24
- Towards flexible SDN-based management for cloud-based mobile networks; NOMS 2016 - 2016 IEEE/IFIP Network Operations and Management Symposium; 2016; 10.1109/NOMS.2016.7502846
- DevOps for IoT Applications Using Cellular Networks and Cloud; 2016 IEEE 4th International Conference on Future Internet of Things and Cloud (FiCloud); 2016; 10.1109/FiCloud.2016.55
- Network slicing management & prioritization in 5G mobile systems; European Wireless 2016; 22th European Wireless Conference; 2016;
- Role-based campus network slicing; 2016 IEEE 24th International Conference on Network Protocols (ICNP); 2016; 10.1109/ICNP.2016.7785315
- Packet forwarding for heterogeneous technologies for integrated fronthaul/backhaul; 2016 European Conference on Networks and Communications (EuCNC); 2016; 10.1109/EuCNC.2016.7561019
- Network slicing as a service: enabling enterprises' own software-defined cellular networks; IEEE Communications Magazine; 2016; 10.1109/MCOM.2016.7509393
- OpenTag: Tag-Based Network Slicing for Wide-Area Coordinated In-Network Packet Processing; 2011 IEEE International Conference on Communications Workshops (ICC); 2011; 10.1109/iccw.2011.5963588
- Multi-tenant 5G Network Slicing Architecture with Dynamic Deployment of Virtualized Tenant Management and Orchestration (MANO) Instances; ECOC 2016; 42nd European Conference on Optical Communication; 2016;
- Towards automated service-oriented lifecycle management for 5G networks; 2015 IEEE 20th Conference on Emerging Technologies & Factory Automation (ETFA); 2015; 10.1109/ETFA.2015.7301660
- Impact of network slicing on 5G Radio Access Networks; 2016 European Conference on Networks and Communications (EuCNC); 2016; 10.1109/EuCNC.2016.7561023
- Network as a Service - A Demo on 5G Network Slicing; 2016 28th International Teletraffic Congress (ITC 28); 2016; 10.1109/ITC-28.2016.136
- Future mobile core network for efficient service operation; Proceedings of the 2015 1st IEEE Conference on Network Softwarization (NetSoft); 2015; 10.1109/NETSOFT.2015.7116190
- Applications of wide-area network slicing for improving cloud platform access by OpenTag; 2012 Fourth International Conference on Communication Systems and Networks (COMSNETS 2012); 2012; 10.1109/COMSNETS.2012.6151302
- Network slicing architecture for 5G network; 2016 International Conference on Information and Communication Technology Convergence (ICTC); 2016; 10.1109/ICTC.2016.7763354
- Reshaping the Mobile core network via function decomposition and network slicing for the 5G era; 2016 IEEE Wireless Communications and Networking Conference Workshops (WCNCW); 2016; 10.1109/WCNCW.2016.7552681
- NVS: A Substrate for Virtualizing Wireless Resources in Cellular Networks; IEEE/ACM Transactions on Networking; 2012; 10.1109/TNET.2011.2179063
- Transmit beamforming for QoE improvement in C-RAN with mobile virtual network operators; 2016 IEEE International Conference on Communications (ICC); 2016; 10.1109/ICC.2016.7511364
- Fixed-mobile convergence towards the 5G era: Convergence 2.0: The past, present and future of FMC standardization; 2016 IEEE Conference on Standards for Communications and Networking (CSCN); 2016; 10.1109/CSCN.2016.7785155

Additional References (II)

Standards News; IEEE Communications Magazine; 2016; 10.1109/M-COM.2016.7785881

Software Defined Networking (SDN) for Aeronautical communications; 2013 IEEE/AIAA 32nd Digital Avionics Systems Conference (DASC); 2013; 10.1109/DASC.2013.6719632

Security considerations in OpenTag network; 2014 26th International Teletraffic Congress (ITC); 2014; 10.1109/ITC.2014.6932977

Uploading a paper to test this feature; Venue Test; 1985; \N

Energy-efficiency enablers and operations in software-defined environments; NOMS 2016 - 2016 IEEE/IFIP Network Operations and Management Symposium; 2016; 10.1109/NOMS.2016.7502947

5G Radio Access Network Architecture: Design Guidelines and Key Considerations; IEEE Communications Magazine; 2016; 10.1109/MCOM.2016.1600147CM

Network Resource Management and QoS in SDN-Enabled 5G Systems; 2015 IEEE Global Communications Conference (GLOBECOM); 2015; 10.1109/GLOCOM.2015.7417376

Network Slicing for 5G with SDN/NFV: Concepts, Architectures, and Challenges; IEEE Communications Magazine; 2017; 10.1109/MCOM.2017.1600935

From network sharing to multi-tenancy: The 5G network slice broker; IEEE Communications Magazine; 2016; 10.1109/MCOM.2016.7514161

Mobile network architecture evolution toward 5G; IEEE Communications Magazine; 2016; 10.1109/MCOM.2016.7470940

VeRTIGO: Network Virtualization and Beyond; 2012 European Workshop on Software Defined Networking; 2012; 10.1109/EWSDN.2012.19

HINC - Harmonizing Diverse Resource Information across IoT, Network Functions, and Clouds; 2016 IEEE 4th International Conference on Future Internet of Things and Cloud (FiCloud); 2016; 10.1109/FiCloud.2016.52

Information Exchange Management as a Service for Network Function Virtualization Environments; IEEE Transactions on Network and Service Management; 2016; 10.1109/TNSM.2016.2587664

Multi-Domain Orchestration for NFV: Challenges and Research Directions; 2016 15th International Conference on Ubiquitous Computing and Communications and 2016 International Symposium on Cyberspace and Security (IUCC-CSS); 2016; 10.1109/IUCC-CSS.2016.034

OpenFlow-based content-centric networking architecture and router implementation; 2013 Future Network & Mobile Summit; 2013;

An optical SDN Controller for Transport Network virtualization and autonomic operation; 2013 IEEE Globecom Workshops (GC Wkshps); 2013; 10.1109/GLOCOMW.2013.6825156

Additional References (III)

Cost efficient network slicing for optical packet switched torus data centers; 2017 IEEE International Conference on Communications (ICC); 2017; 10.1109/ICC.2017.7996502

Fixed Access Network Sharing; IEEE Communications Standards Magazine; 2017; 10.1109/MCOMSTD.2017.1600001ST

PERMIT: Network Slicing for Personalized 5G Mobile Telecommunications; IEEE Communications Magazine; 2017; 10.1109/MCOM.2017.1600947

Modeling profit of sliced 5G networks for advanced network resource management and slice implementation; 2017 IEEE Symposium on Computers and Communications (ISCC); 2017; 10.1109/ISCC.2017.8024590

Toward Enforcing Network Slicing on RAN: Flexibility and Resources Abstraction; IEEE Communications Magazine; 2017; 10.1109/MCOM.2017.1601119

Virtualized cloud video services; 2017 25th Signal Processing and Communications Applications Conference (SIU); 2017; 10.1109/SIU.2017.7960240

Virtual network forwarding graph embedding based on Tabu Search; 2017 9th International Conference on Wireless Communications and Signal Processing (WCSP); 2017; 10.1109/WCSP.2017.8171072

Dynamic Network Slicing for Multitenant Heterogeneous Cloud Radio Access Networks; IEEE Transactions on Wireless Communications; 2018; 10.1109/TWC.2017.2789294

5G-ICN: Delivering ICN Services over 5G Using Network Slicing; IEEE Communications Magazine; 2017; 10.1109/MCOM.2017.1600938

Slice architecture for 5G core network; 2017 Ninth International Conference on Ubiquitous and Future Networks (ICUFN); 2017; 10.1109/ICUFN.2017.7993854

A network traffic shunt system in SDN network; 2017 International Conference on Computer, Information and Telecommunication Systems (CITS); 2017; 10.1109/CITS.2017.8035281

Mobile Network Sharing; Broadband Coverage in Germany; 11. ITG-Symposium; 2017;

Analog Coded SoftCast: A Network Slice Design for Multimedia Broadcast/Multicast; IEEE Transactions on Multimedia; 2017; 10.1109/TMM.2017.2733303

BLESS: Bluetooth low energy service switching using SDN; 2017 IEEE Conference on Computer Communications Workshops (INFOCOM WKSHPS); 2017; 10.1109/INFOCOMW.2017.8116440

Multi-Tenant Slicing for Spectrum Management on the Road to 5G; IEEE Wireless Communications; 2017; 10.1109/MWC.2017.1700138

Network slicing in 5G: An auction-based model; 2017 IEEE International Conference on Communications (ICC); 2017; 10.1109/ICC.2017.7996490

On end-to-end approach for slice isolation in 5G networks. Fundamental challenges; 2017 Federated Conference on Computer Science and Information Systems (FedCSIS); 2017; 10.15439/2017F228

Additional References (IV)



- Programmable access and edge cloud architecture; 2017 Optical Fiber Communications Conference and Exhibition (OFC); 2017;
- Software Defined Networking Enabled Wireless Network Virtualization: Challenges and Solutions; IEEE Network; 2017; 10.1109/MNET.2017.1600248
- 5G-Crosshaul: An SDN/NFV Integrated Fronthaul/Backhaul Transport Network Architecture; IEEE Wireless Communications; 2017; 10.1109/MWC.2017.1600181WC
- Network slicing with flexible mobility and QoS/QoE support for 5G Networks; 2017 IEEE International Conference on Communications Workshops (ICC Workshops); 2017; 10.1109/ICCW.2017.7962821
- NFV enabling network slicing for 5G; 2017 20th Conference on Innovations in Clouds, Internet and Networks (ICIN); 2017; 10.1109/ICIN.2017.7899415
- 5G NORMA: System architecture for programmable & multi-tenant 5G mobile networks; 2017 European Conference on Networks and Communications (EuCNC); 2017; 10.1109/EuCNC.2017.7980662
- Using small cells for enhancing 5G network facilities; 2017 IEEE Conference on Network Function Virtualization and Software Defined Networks (NFV-SDN); 2017; 10.1109/NFV-SDN.2017.8169871
- Learning in SDN-based multi-tenant cellular networks: A game-theoretic perspective; 2017 IFIP/IEEE Symposium on Integrated Network and Service Management (IM); 2017; 10.23919/INM.2017.7987414
- Network Slicing Based 5G and Future Mobile Networks: Mobility, Resource Management, and Challenges; IEEE Communications Magazine; 2017; 10.1109/MCOM.2017.1600940
- First experimental demonstration of autonomic slice networking; 2017 Optical Fiber Communications Conference and Exhibition (OFC); 2017;
- Optimising 5G infrastructure markets: The business of network slicing; IEEE INFOCOM 2017 - IEEE Conference on Computer Communications; 2017; 10.1109/INFOCOM.2017.8057045
- A way forward for accommodating NFV in 3GPP 5G systems; 2017 International Conference on Information and Communication Technology Convergence (ICTC); 2017; 10.1109/ICTC.2017.8190953
- Cost-efficient method for managing network slices in a multi-service 5G core network; 2017 IFIP/IEEE Symposium on Integrated Network and Service Management (IM); 2017; 10.23919/INM.2017.7987451
- Network Slicing for Service-Oriented Networks Under Resource Constraints; IEEE Journal on Selected Areas in Communications; 2017; 10.1109/JSAC.2017.2760147
- Network Slicing to Enable Scalability and Flexibility in 5G Mobile Networks; IEEE Communications Magazine; 2017; 10.1109/MCOM.2017.1600920
- Architecture modularisation for next generation mobile networks; 2017 European Conference on Networks and Communications (EuCNC); 2017; 10.1109/EuCNC.2017.7980664
- Compete or Collaborate: Architectures for Collaborative DASH Video Over Future Networks; IEEE Transactions on Multimedia; 2017; 10.1109/TMM.2017.2736638

Additional References (V)

Energy-efficient resource allocation in delay-aware wireless virtualized networks; 2017 9th International Conference on Wireless Communications and Signal Processing (WCSP); 2017; 10.1109/WCSP.2017.8171173

Network Slicing in Fog Radio Access Networks: Issues and Challenges; IEEE Communications Magazine; 2017; 10.1109/MCOM.2017.1700523

Open multi-access edge computing and distributed mobility management with RINA; 2017 IEEE Conference on Network Function Virtualization and Software Defined Networks (NFV-SDN); 2017; 10.1109/NFV-SDN.2017.8169850

Orchestrating for deployment of network slicing; 2017 Wireless Telecommunications Symposium (WTS); 2017; 10.1109/WTS.2017.7943526

Sliced NFV service chaining in mobile edge clouds; 2017 19th Asia-Pacific Network Operations and Management Symposium (APNOMS); 2017; 10.1109/APNOMS.2017.8094132

Software Defined Space-Air-Ground Integrated Vehicular Networks: Challenges and Solutions; IEEE Communications Magazine; 2017; 10.1109/MCOM.2017.1601156

Shared Spectrum Access Communications: A Neutral Host Micro Operator Approach; IEEE Journal on Selected Areas in Communications; 2017; 10.1109/JSAC.2017.2710021

Statistical multiplexing and traffic shaping games for network slicing; 2017 15th International Symposium on Modeling and Optimization in Mobile, Ad Hoc, and Wireless Networks (WiOpt); 2017; 10.23919/WIOPT.2017.7959883

Radio access network slicing based on C/U plane separation; China Communications; 2017; 10.1109/CC.2017.8246330

Network Slicing for 5G: Challenges and Opportunities; IEEE Internet Computing; 2017; 10.1109/MIC.2017.3481355

Table of contents; 2017 IEEE Conference on Standards for Communications and Networking (CSCN); 2017; 10.1109/CSCN.2017.8088588

The algorithmic aspects of network slicing; IEEE Communications Magazine; 2017; 10.1109/MCOM.2017.1600939

5G Network Slicing for Vehicle-to-Everything Services; IEEE Wireless Communications; 2017; 10.1109/MWC.2017.1600408

Channel Equalization and Interference Analysis for Uplink Narrowband Internet of Things (NB-IoT); IEEE Communications Letters; 2017; 10.1109/LCOMM.2017.2705710

A scalable SDN slicing scheme for multi-domain fog/cloud services; 2017 IEEE Conference on Network Softwarization (NetSoft); 2017; 10.1109/NETSOFT.2017.8004244

End-to-end network slicing enabled through network function virtualization; 2017 IEEE Conference on Standards for Communications and Networking (CSCN); 2017; 10.1109/CSCN.2017.8088594

Additional References (VI)

Network Slicing & Softwarization: A Survey on Principles, Enabling Technologies & Solutions NESMO: Network slicing management and orchestration framework; IEEE Communications Surveys & Tutorials ; DOI: 10.1109/COMST.2018.2815638

2017 IEEE International Conference on Communications Workshops (ICC Workshops); 2017; 10.1109/ICCW.2017.7962822

SDN/NFV-based end to end network slicing for 5G multi-tenant networks; 2017 European Conference on Networks and Communications (EuCNC); 2017; 10.1109/EuCNC.2017.7980670

Network slicing for 5G systems: A review from an architecture and standardization perspective; 2017 IEEE Conference on Standards for Communications and Networking (CSCN); 2017; 10.1109/CSCN.2017.8088595

SDN implementation of slicing and fast failover in 5G transport networks; 2017 European Conference on Networks and Communications (EuCNC); 2017; 10.1109/EuCNC.2017.7980671

Network Slices toward 5G Communications: Slicing the LTE Network; IEEE Communications Magazine; 2017; 10.1109/MCOM.2017.1600936

Network slicing games: Enabling customization in multi-tenant networks; IEEE INFOCOM 2017 - IEEE Conference on Computer Communications; 2017; 10.1109/INFOCOM.2017.8057046

Fully automated peer service orchestration of cloud and network resources using ACTN and CSO; 2017 Optical Fiber Communications Conference and Exhibition (OFC); 2017;

Heterogeneous Public Safety Network Architecture Based on RAN Slicing; IEEE Access; 2017; 10.1109/ACCESS.2017.2768800

Joint resource allocation and caching placement for network slicing in fog radio access networks; 2017 IEEE 18th International Workshop on Signal Processing Advances in Wireless Communications (SPAWC); 2017; 10.1109/SPAWC.2017.8227791

LAA-as-a-service as key enabler in 5G dynamic radio topologies; 2017 IEEE Conference on Standards for Communications and Networking (CSCN); 2017; 10.1109/CSCN.2017.8088612

Location-aware dynamic network provisioning; 2017 19th Asia-Pacific Network Operations and Management Symposium (APNOMS); 2017; 10.1109/APNOMS.2017.8094142

On Radio Access Network Slicing from a Radio Resource Management Perspective; IEEE Wireless Communications; 2017; 10.1109/MWC.2017.1600220WC

Virtualized authentication, authorization and accounting (V-AAA) in 5G networks; 2017 IEEE Conference on Standards for Communications and Networking (CSCN); 2017; 10.1109/CSCN.2017.8088618

Service-Tailored User-Plane Design Framework and Architecture Considerations in 5G Radio Access Networks; IEEE Access; 2017; 10.1109/ACCESS.2017.2736579

5G-Crosshaul Network Slicing: Enabling Multi-Tenancy in Mobile Transport Networks; IEEE Communications Magazine; 2017; 10.1109/MCOM.2017.1600921

Filtered OFDM Systems, Algorithms and Performance Analysis for 5G and Beyond; IEEE Transactions on Communications; 2017; 10.1109/TCOMM.2017.2771242

Network Slicing Tutorial – IEEE NetSoft 2018 – Montreal 29th June 2018

Additional References (VII)

A Cloud-Native Approach to 5G Network Slicing; IEEE Communications Magazine; 2017; 10.1109/MCOM.2017.1600942

Hybrid multi-tenant cache management for virtualized ISP networks; Journal of Network and Computer Applications; 2016; \N

Demystifying network slicing: From theory to practice; 2017 IFIP/IEEE Symposium on Integrated Network and Service Management (IM); 2017; 10.23919/INM.2017.7987450

Efficient caching resource allocation for network slicing in 5G core network; IET Communications; 2017; 10.1049/iet-com.2017.0539

A game-theoretic approach to network slicing; 2017 27th International Telecommunication Networks and Applications Conference (ITNAC); 2017; 10.1109/ATNAC.2017.8215397

Automatic mapping of cyber security requirements to support network slicing in software-defined networks; 2017 22nd IEEE International Conference on Emerging Technologies and Factory Automation (ETFA); 2017; 10.1109/ETFA.2017.8247728

Mobile traffic forecasting for maximizing 5G network slicing resource utilization; IEEE INFOCOM 2017 - IEEE Conference on Computer Communications; 2017; 10.1109/INFOCOM.2017.8057230

Next Generation Emergency Communication Systems via Software Defined Networks; 2014 Third GENI Research and Educational Experiment Workshop; 2014; 10.1109/GREE.2014.26

Robustness-based resource trading with optimization problem for network slicing; 2017 IEEE International Conference on Consumer Electronics - Taiwan (ICCE-TW); 2017; 10.1109/ICCE-China.2017.7991133

Integrated NFV/SDN Architectures: A Systematic Literature Review; ACM Computing Surveys; 2018; \N

Cascading of tenant SDN and cloud controllers for 5G network slicing using transport API and openstack API; 2017 Optical Fiber Communications Conference and Exhibition (OFC); 2017;

Demonstration of survivable vSD-EON slicing with automatic data plane restoration to support reliable video streaming; 2017 Optical Fiber Communications Conference and Exhibition (OFC); 2017;

Description of Network Slicing Concept; Description of Network Slicing Concept; 2016;

Spectrum and Network Density Management in 5G Ultra-Dense Networks; IEEE Wireless Communications; 2017; 10.1109/MWC.2017.1700087

A Resource Allocation Framework for Network Slicing; IEEE INFOCOM 2018; 2018; \N

Selection and Dimensioning of Slice-Based RAN Controller for Adaptive Radio Resource Management; 2017 IEEE Wireless Communications and Networking Conference (WCNC); 2017; 10.1109/WCNC.2017.7925932

5G Architectural Design Patterns; 2016 IEEE International Conference on Communications Workshops (ICC); 2016; 10.1109/ICCW.2016.7503760

An Architecture to Support Autonomic Slice Networking; Journal of Lightwave Technology; 2017; 10.1109/JLT.2017.2748233

Additional References (VIII)

5G-XHaul: Enabling Scalable Virtualization for Future 5G Transport Networks; 2016 15th International Conference on Ubiquitous Computing and Communications and 2016 International Symposium on Cyberspace and Security (IUCC-CSS); 2016; 10.1109/IUCC-CSS.2016.032

Network Slicing in 5G: Survey and Challenges; IEEE Communications Magazine; 2017; 10.1109/MCOM.2017.1600951

Multi-level reliability architecture for network slicing in metro networks; 2017 IEEE International Symposium on Local and Metropolitan Area Networks (LANMAN); 2017; 10.1109/LANMAN.2017.7972148

Joint Application Admission Control and Network Slicing in Virtual Sensor Networks; IEEE Internet of Things Journal; 2017; 10.1109/JIOT.2017.2769446

Dynamic role assignment in Software-Defined Wireless Networks; 2017 IEEE Symposium on Computers and Communications (ISCC); 2017; 10.1109/ISCC.2017.8024619